

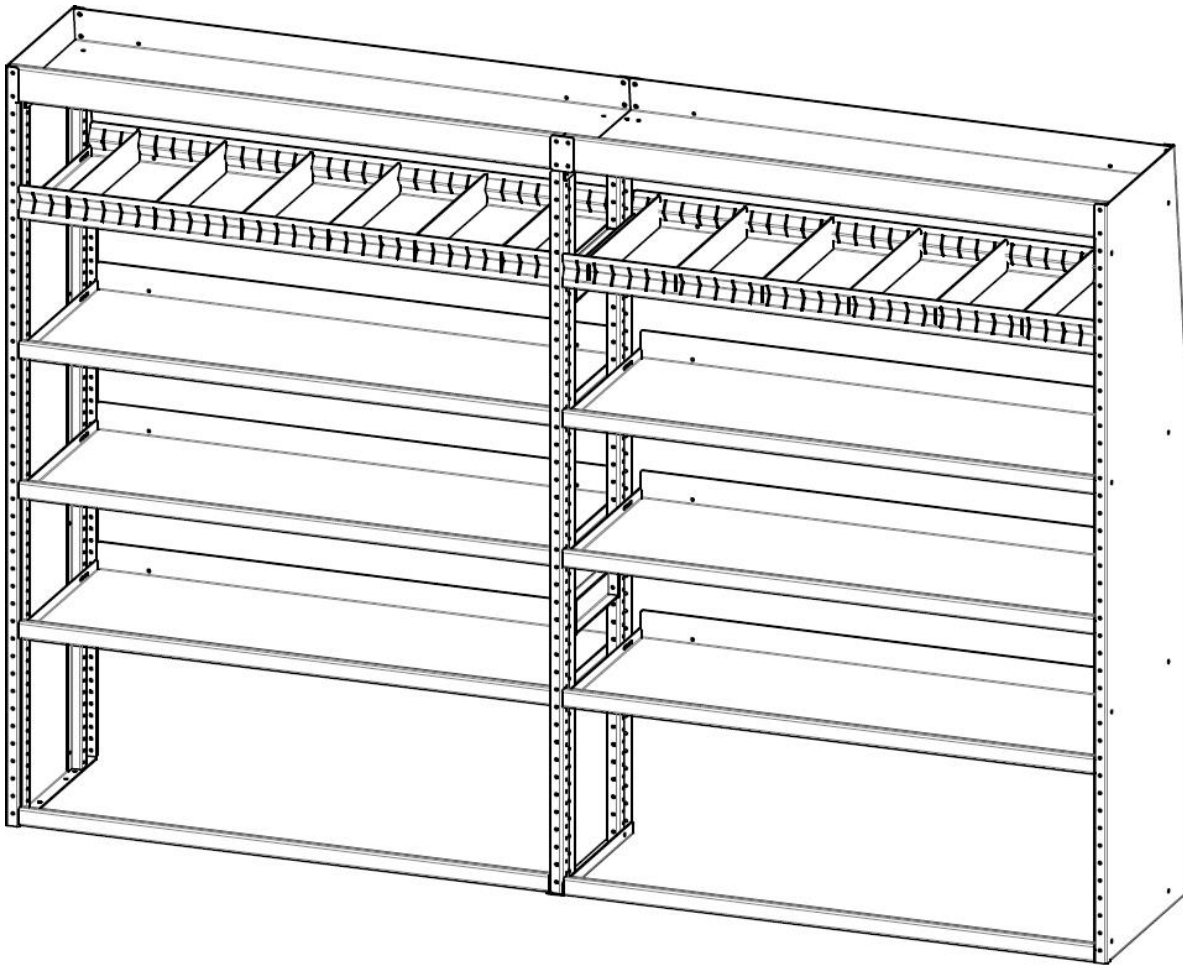



Assembly Guide

Double Section Tapered Shelving
with Standard Top Tray

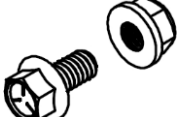

	A ¼-20 x 5/8" Pan Head Bolt		B ¼-20 x 5/8" Hex Head Flanged Bolt		C #10 x 1" Self-drilling Tek Screw
---	---------------------------------------	---	--	--	--

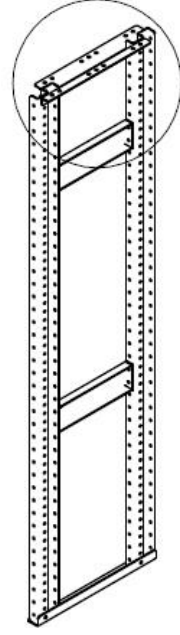
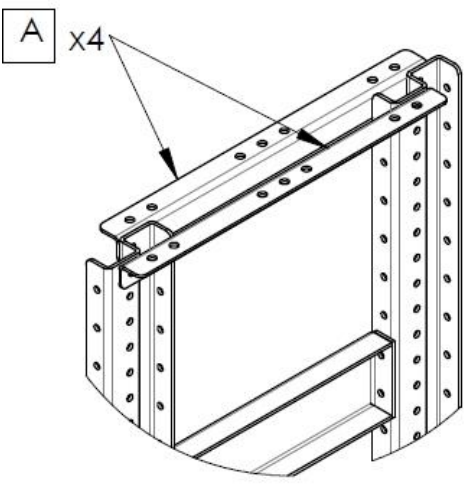
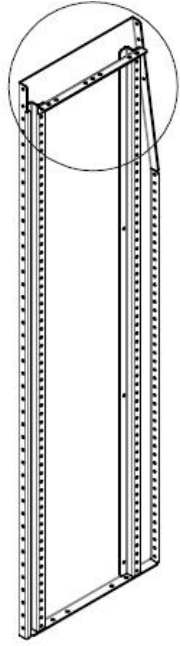
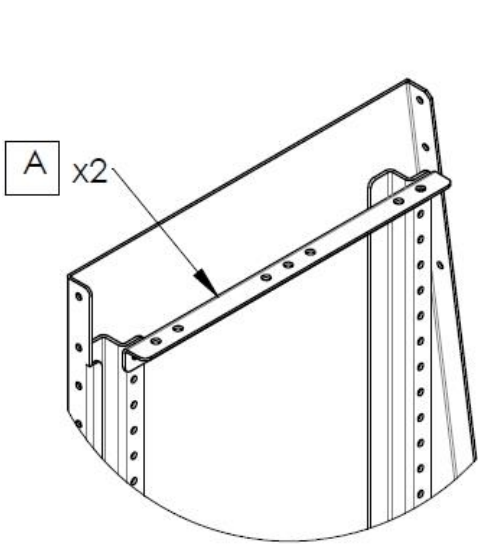

Step 1

- Bolt one L-bracket to each End Panel
- Bolt two L-brackets to the Center Support

Note: L-brackets must be flush to the top of the rails

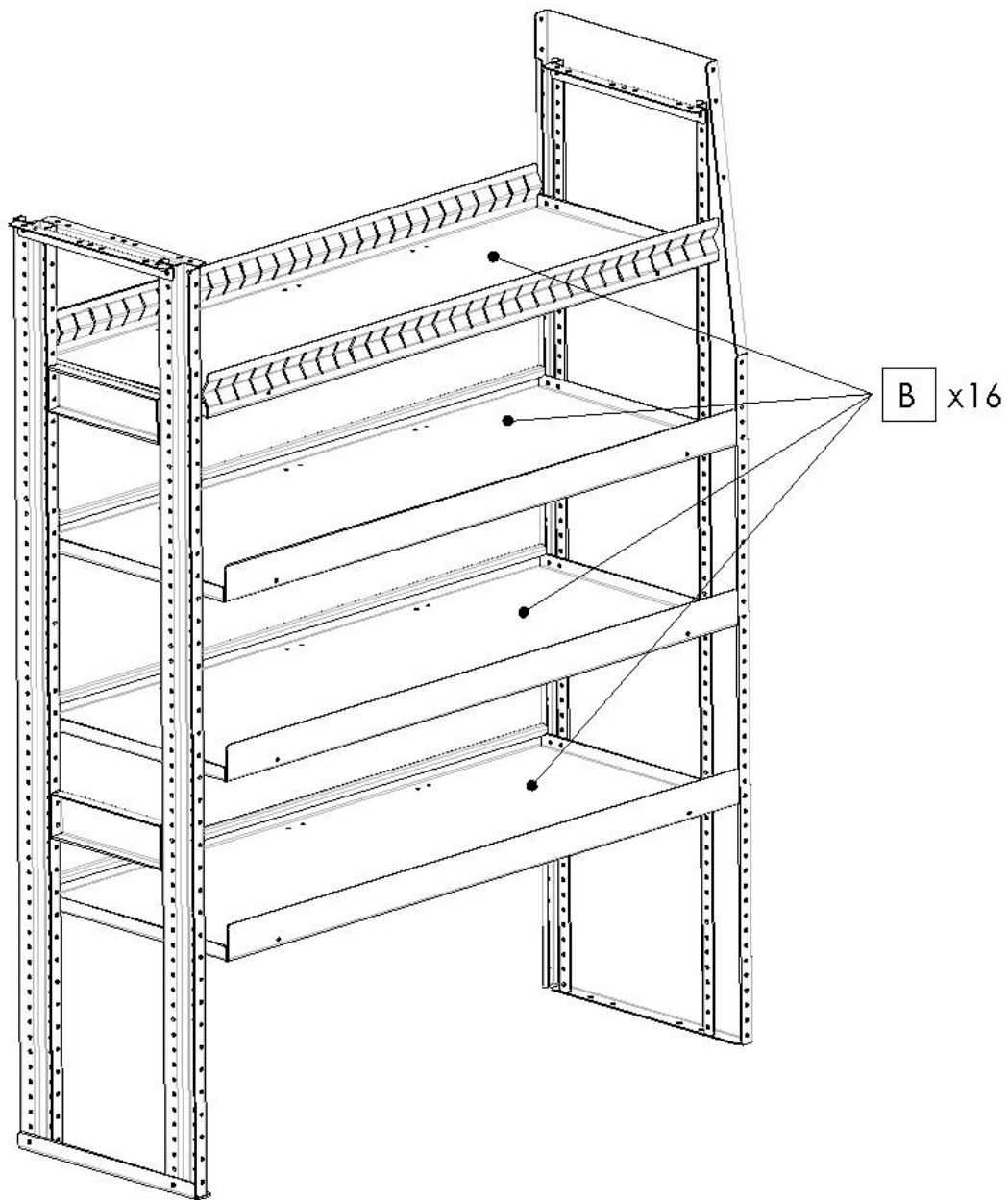

Step 2

- Install the shelves for the first section from top to bottom.

Note:

- This is most easily done with shelving unit face down on a level surface
- Slotted holes on each shelf go to the back rail
- Measure and mark on the rails the desired shelf heights
- The topmost shelf is shallower. Lower shelves are full depth.
- Shelves may be mounted upside down or tilted up/down to fit your needs

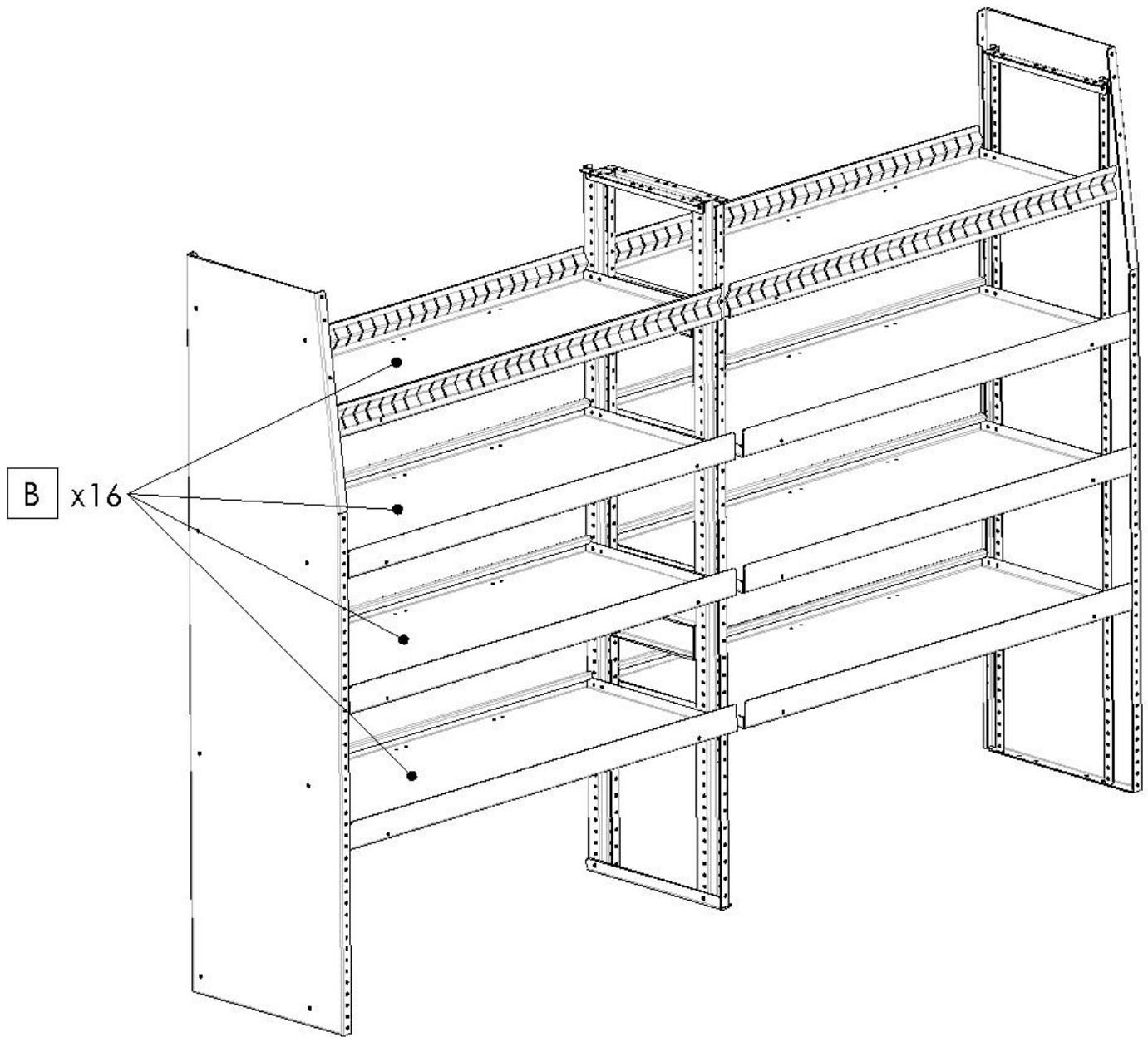

Step 3

- Install the shelves for the second section from top to bottom.

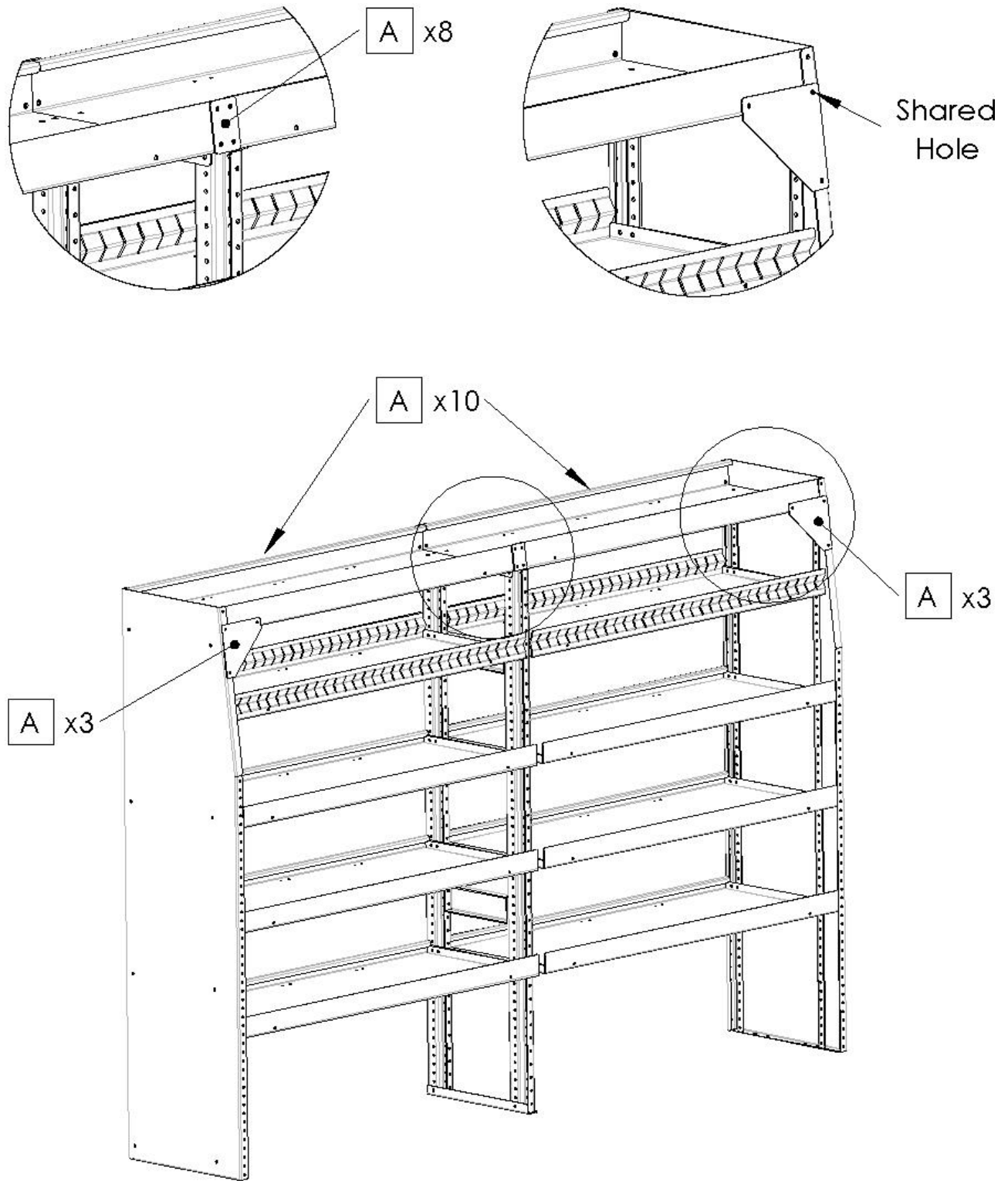

Step 4

- Install the two Top Trays and the two Angle Supports
- Bolt the two Connecting Plates on the front and back of where the trays meet in the middle

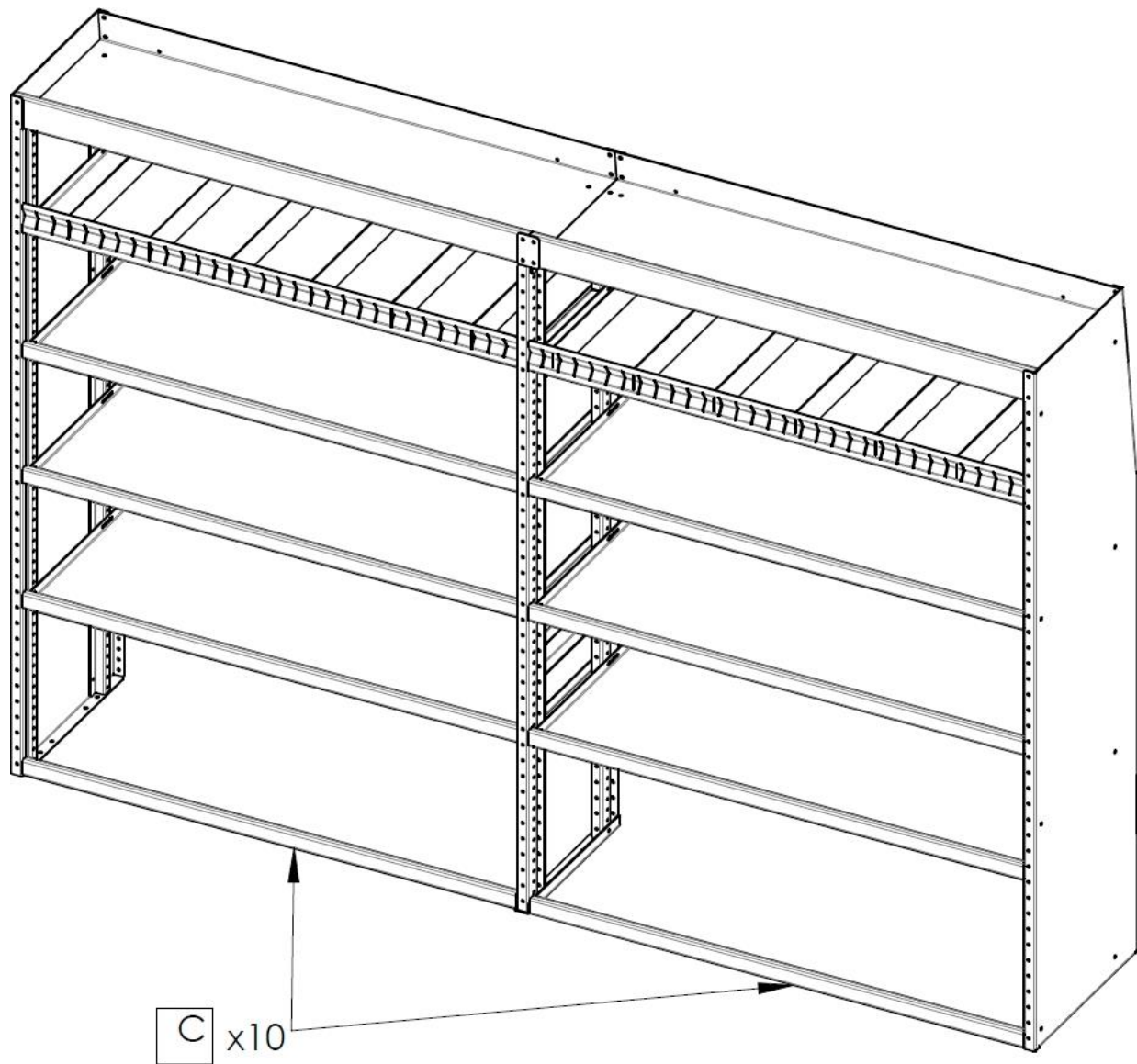

Step 5

- Check all bolts are tight
- Lift the shelving unit into the van and use the provided installation hardware to fasten it to the wall and floor. Follow the install guide.
- Screw each bottom lip to the floor (optional).
- Insert the slotted shelf dividers at desired spacing (if applicable).

Note: Slightly twisting each divider will allow for a tighter and quieter fit