

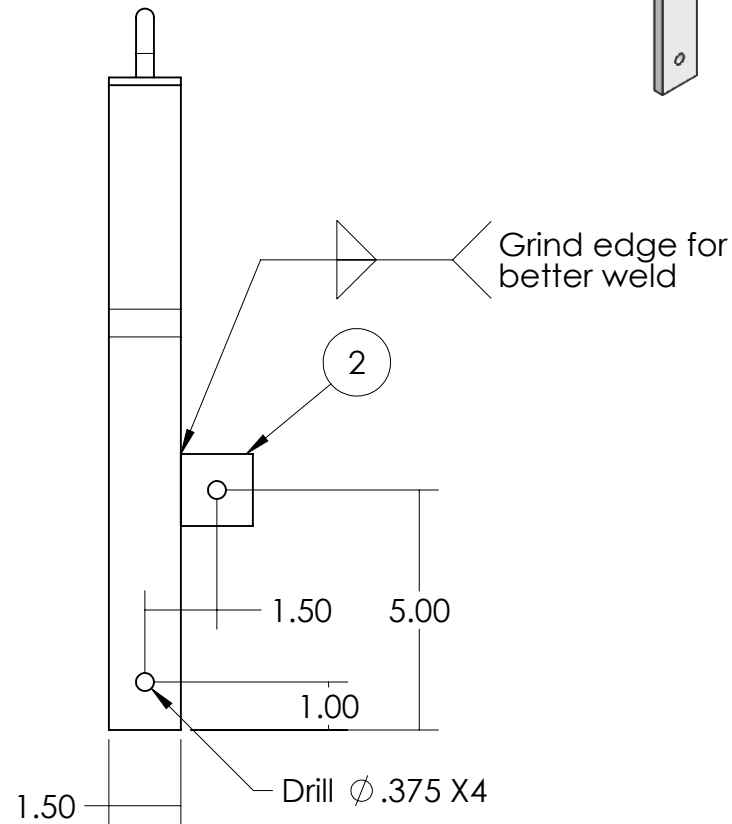

CUT LIST			
#	PART	QTY.	SIZE
1	SIDE BAR	2	3/8" X 1 1/2" X 14 1/2"
2	TAB	2	3/8" X 1 1/2" X 1 1/2"
3	TOP BAR	1	3/8" X 1 1/2" X 4 3/4"
4	134003	1	Look to Loop Drawing

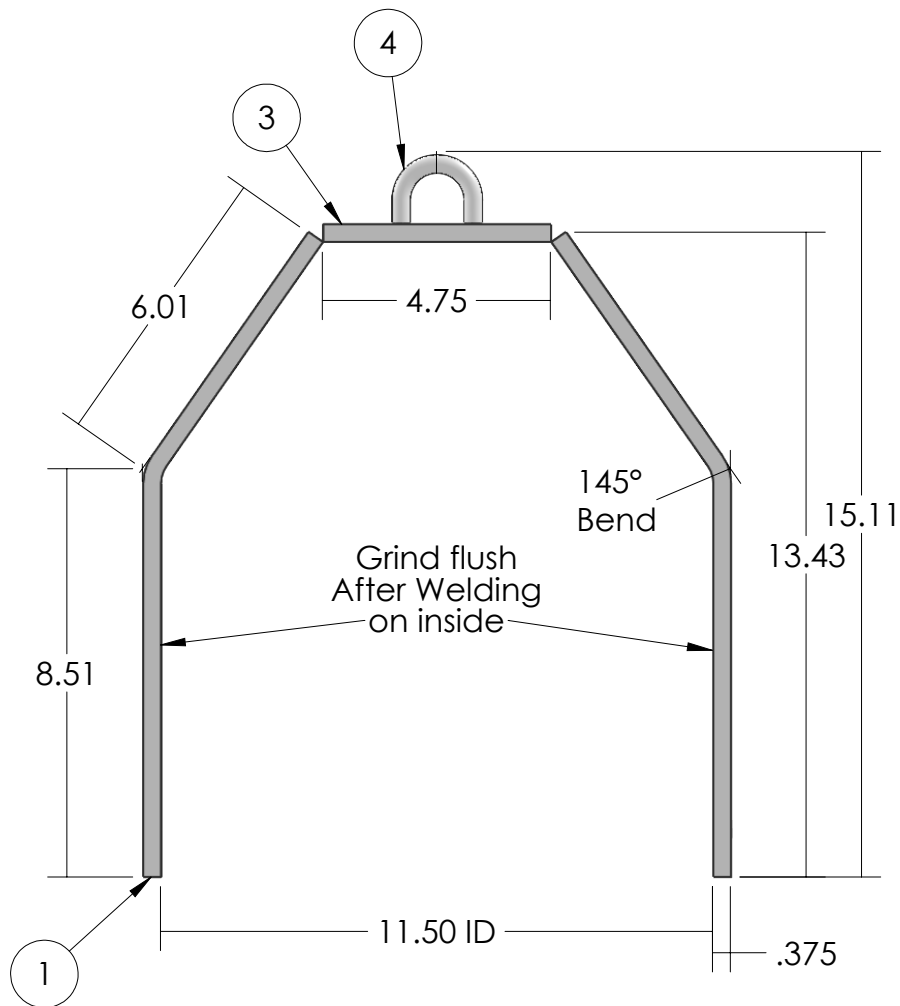
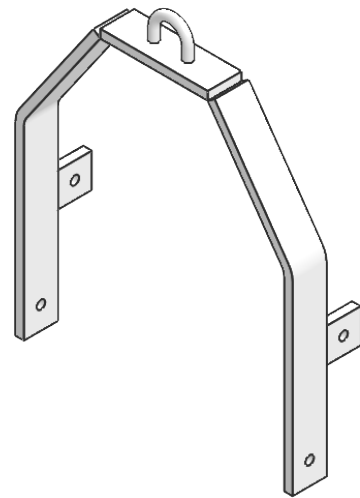

NOTE:  
 • USE JIG  
 • CLEAN UP WELDS FOR POWDER COAT  
 • POWDER COAT Mini Texture BLACK

Asm. No.	139002		Description	Spartan 300 Sewer Machine Hook Asm.	
Tolerance	Rev.	Weight	Material	Item No.	
Unless otherwise Specified: Dimensions Are In Inches Fractional ± Angular: Mach ± .1° Bend ± .5° Two Place Decimal ± .05 Three Place Decimal ± .005	--	5.19010 Lbs.	Steel/Black	130002	
 7541 Chapman Ave Unit B Garden Grove, Ca 92841			PROPRIETARY AND CONFIDENTIAL	SIZE	Date
			<small>THE INFORMATION CONTAINED IN THIS DRAWING IS THE SOLE PROPERTY OF J&amp;M TRUCK BODIES. ANY REPRODUCTION IN PART OR AS A WHOLE WITHOUT THE WRITTEN PERMISSION OF J&amp;M TRUCK BODIES IS PROHIBITED.</small>	A	10/14/2024
				Drawn By.	SCALE: 1:4 SHEET 2 OF 8

5

4

3

2

1