

Notes:
 *500Lbs. Lifting Capacity
 *Powdercoated Black

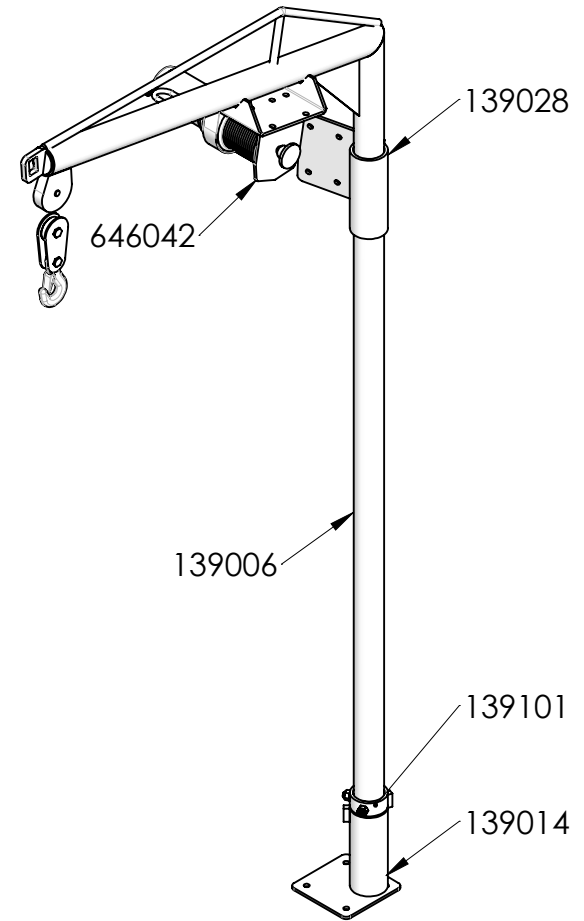
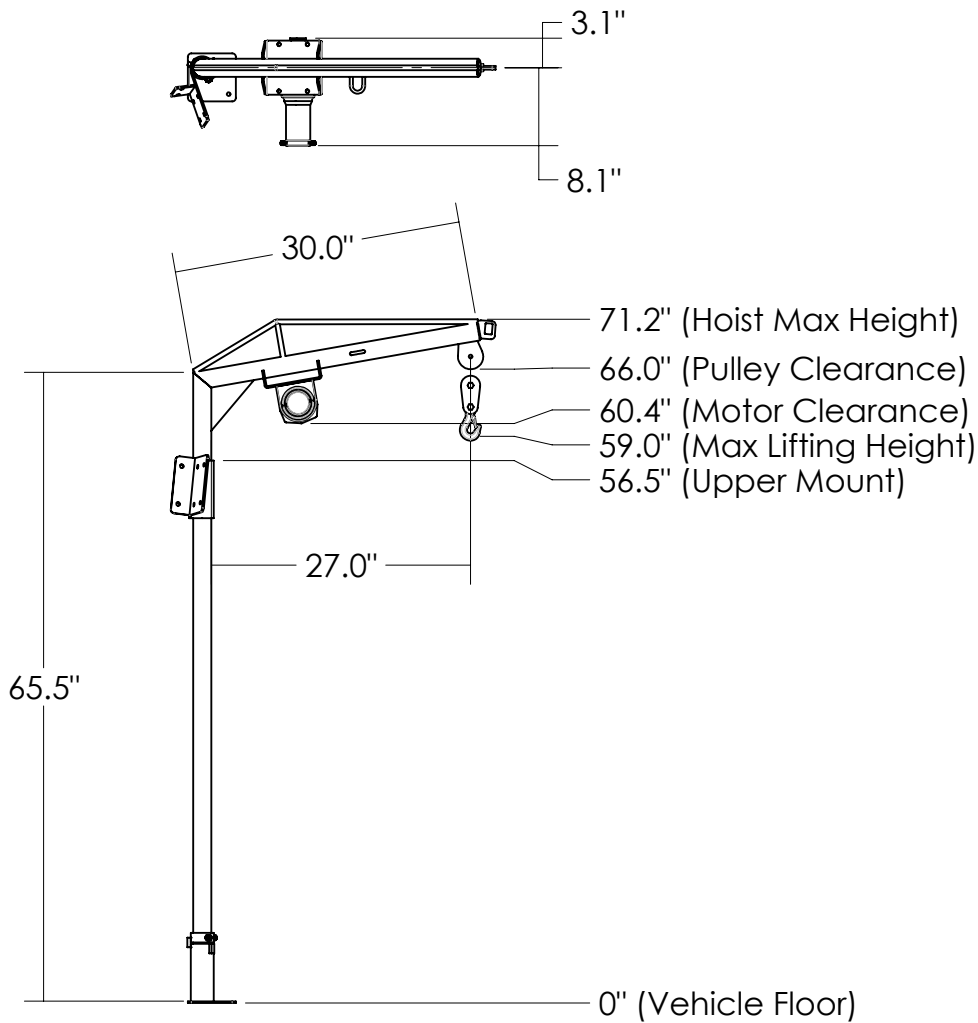

12	642274	6	3/8"-16 x 1" Grade 8 Hex Bolt
11	642205	3	5/16 x 1-1/4" - Flanged Hex Head Sheet Metal Screw
10	642252	6	3/8" SAE Flat Washer - Zinc
9	642256	6	3/8"-16 Nyloc Flange Nut - Zinc
8	649154	1	Hoist Electrical Hardware Kit (not shown)
7	646042	1	Winch Motor - Steel Line 12v With Handheld Remote
6	646001	1	Winch Pulley Block - Attached to Cable on Motor
5	131045	1	Pulley w/ Axle and Cotter Pin
4	139101	1	Pivot Tube Stop Asm
3	139028	1	07+ Sprinter - Upper Mount Asm. - Rear HR Pass.
2	139014	1	Lower Mount Asm. - Corner Base Plate - 5"L x 5"W
1	139006	1	Boom Asm. - 10° x 30" Jib x 65.5" Std. Boom
#	PART NO.	QTY.	DESCRIPTION

Rev. Weight
 -- 46.27 Lbs.

 7541 Chapman Ave Unit B
 Garden Grove, Ca 92841

Description 07+ Sprinter - 12V Electric
 Hoist Kit - Rear HR Pass.

Material Steel Item No. 130021

PROPRIETARY AND CONFIDENTIAL
 THE INFORMATION CONTAINED IN THIS
 DRAWING IS THE SOLE PROPERTY OF
 J&M TRUCK BODIES. ANY
 REPRODUCTION IN PART OR AS A WHOLE
 WITHOUT THE WRITTEN PERMISSION OF
 J&M TRUCK BODIES IS PROHIBITED.

SIZE Date
 A 5/3/2021
 Drawn By: S.Gutierrez
 SCALE: 1:18