

Notes:  
 \*500Lbs. Lifting Capacity  
 \*Powdercoated Black

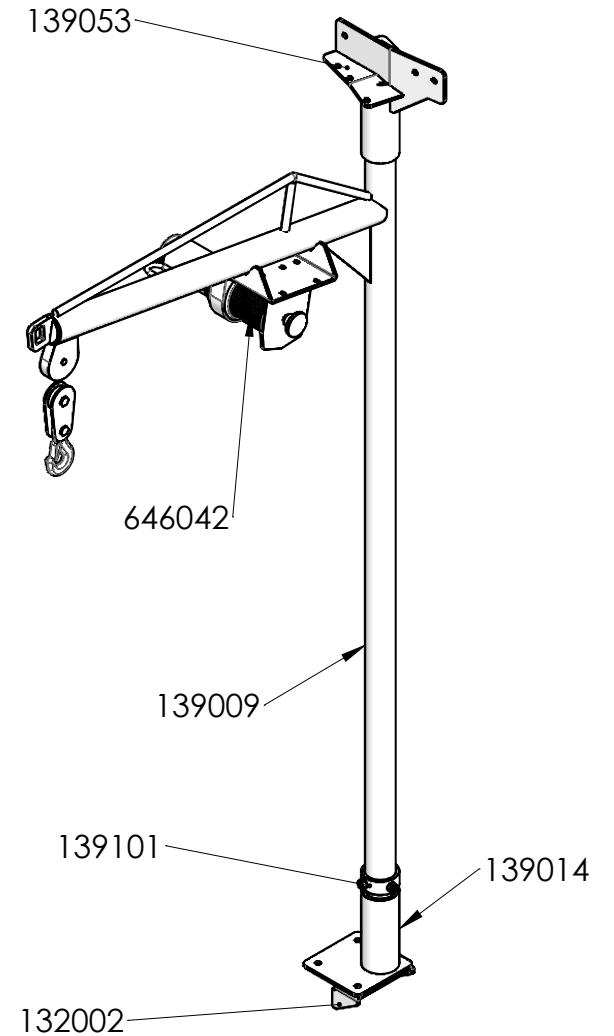

16	642674	3	5/16"-18 x 1" Dome Head Bolt - Stainless
15	642652	6	5/16" SAE Flat washer - Stainless
14	642156	3	5/16-18 Nyloc Flange Nut - Zinc
13	642274	3	3/8"-16 x 1" Grade 8 Hex Bolt - Yellow-Chromate
12	642254	6	3/8" SAE Flat washer - Zinc
11	642256	2	3/8"-16 Nyloc Flange Nut - Zinc
10	642205	2	5/16 x 1-1/4" - Flanged Hex Head Sheet Metal Screw
9	649154	1	Hoist Electrical Hardware Kit (not shown)
8	646042	1	Winch Motor - Steel Line 12v With Handheld Remote
7	646001	1	Winch Pully Block - Attached to Cable on Motor
6	131045	1	Pulley w/ Axle and Cotter Pin
5	132002	1	Lower Mount - Under Support Plate
4	139101	1	Pivot Tube Stop Asm
3	139014	1	Lower Mount Asm. - Corner Base Plate - 5"L x 5"W
2	139053	1	Upper Mount Asm. - 07+ Sprinter - B-Pillar Asm.
1	139009	1	Boom Asm. - 10° x 28.75" Jib x 66"L Extended Boom
#	PART NO.	QTY.	DESCRIPTION

Rev. Weight  
 -- 49.84 Lbs.

  
 7541 Chapman Ave Unit B  
 Garden Grove, Ca 92841

Description 07+ Sprinter - 12V Electric Hoist Kit - Side Door B-Pillar - Passenger Side

Material Mild Steel (Black) Item No. 130047

PROPRIETARY AND CONFIDENTIAL  
 THE INFORMATION CONTAINED IN THIS DRAWING IS THE SOLE PROPERTY OF J&M TRUCK BODIES. ANY REPRODUCTION IN PART OR AS A WHOLE WITHOUT THE WRITTEN PERMISSION OF J&M TRUCK BODIES IS PROHIBITED.

SIZE Date 12/4/2024  
 A Drawn By: S.Gutierrez  
 SCALE: 1:18

# Cut Boom As Shown

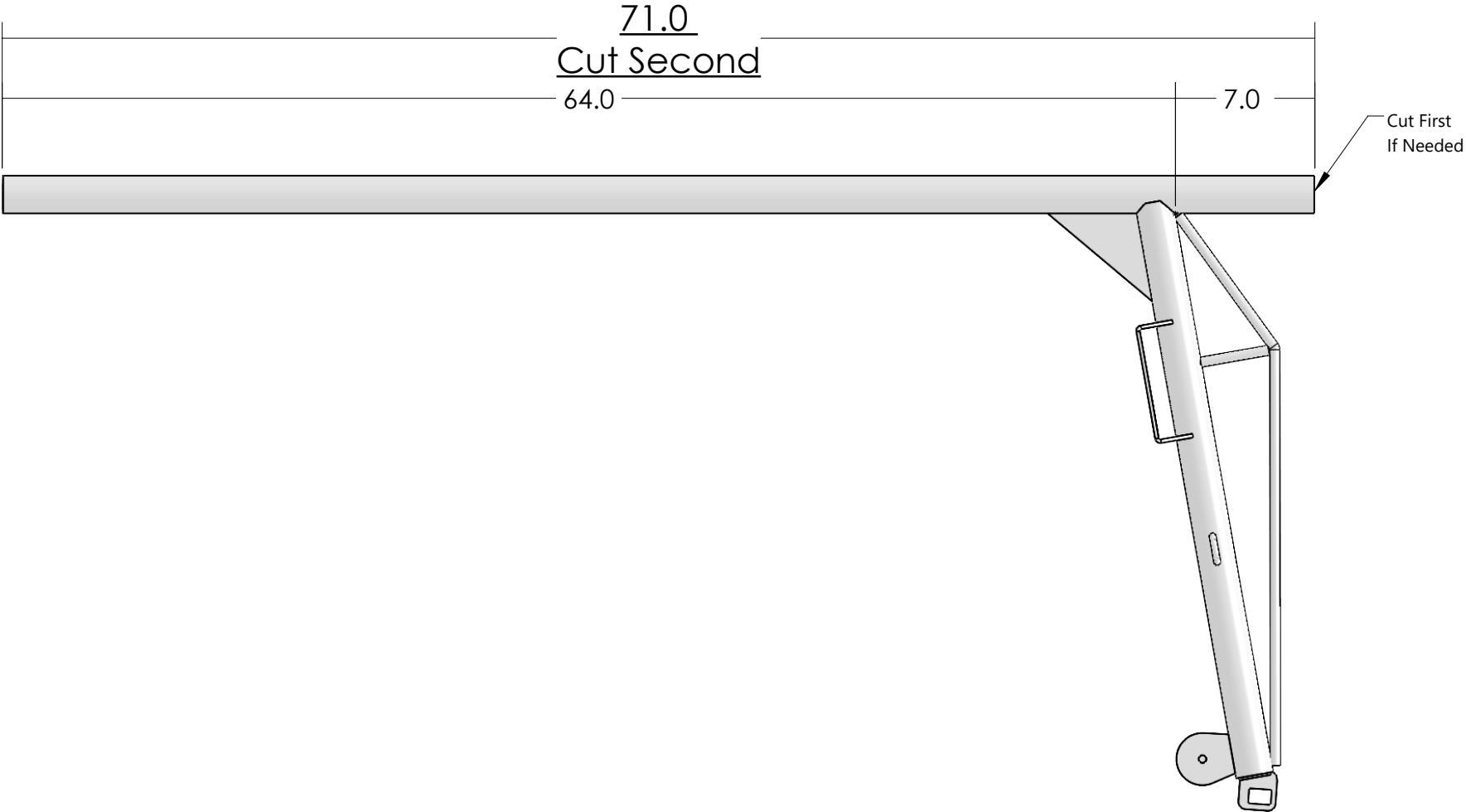

Rev.		Weight		Description	
--				07+ Sprinter - 12V Electric Hoist Kit - Side Door B-Pillar - Passenger Side	
		Lbs.		Material	Item No.
				Mild Steel (Black)	130047
				SIZE	Date
					12/4/2024
				A	Drawn By.
					SCALE: 1:8



7541 Chapman Ave Unit B  
 Garden Grove, Ca 92841