

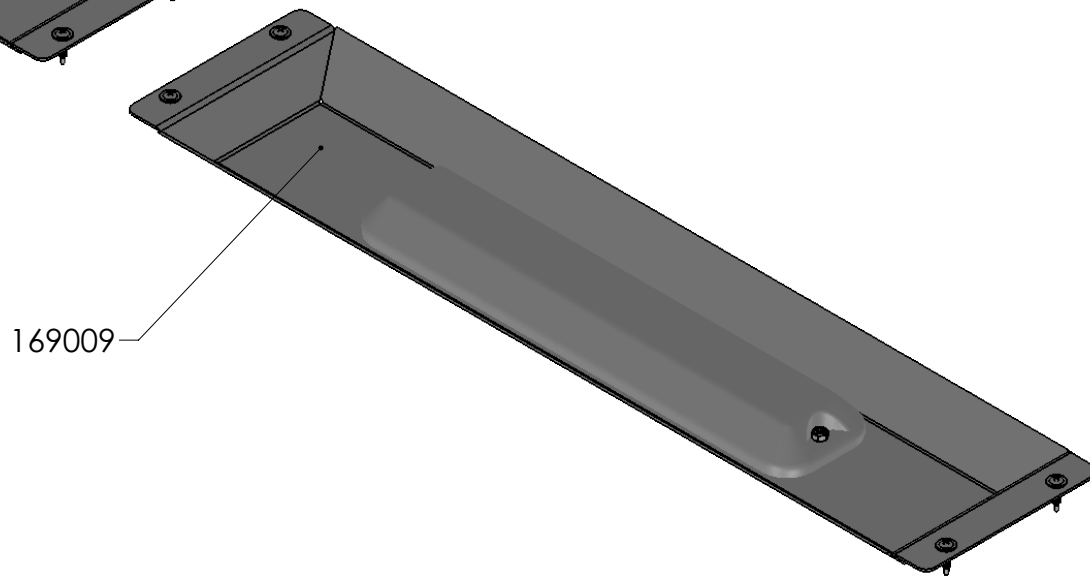

Recommend Light Locations

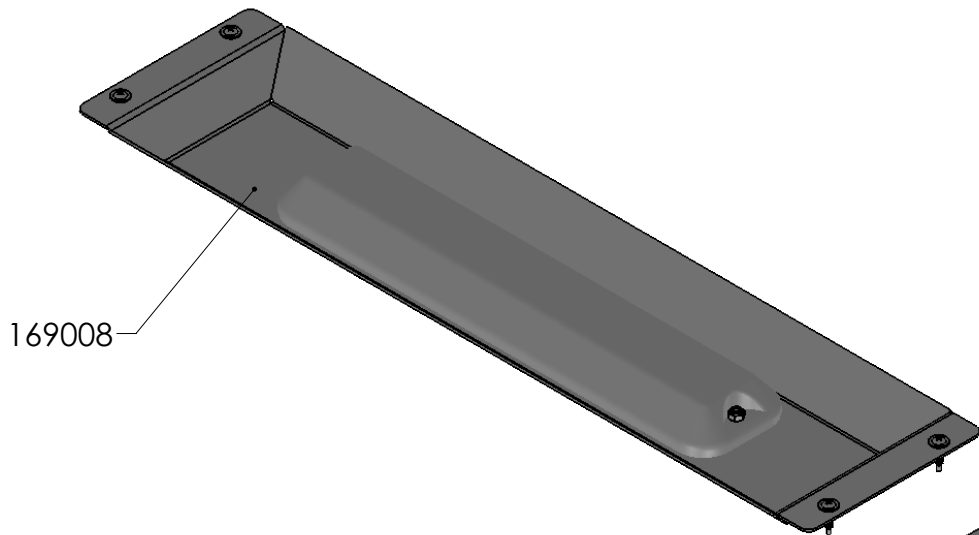

| | | | | | | | | |
|---|----------|------|--|--|---------------------|--|----------------------|-------------|
| | | | | Rev. -- | Weight 3.77712 Lbs. | Description 07+ Sprinter Van 144WB - Double 13" LED Light Kit | Item No. 160002 | |
| 4 | N/A | 1 | 160002_BOM Sheet |  7541 Chapman Ave Unit B Garden Grove, Ca 92841 | | Material PrePainted White Aluminum | Date 8/25/2020 | |
| 3 | 649251 | 1 | Universal Light Electrical and Hardware Kit | | | PROPRIETARY AND CONFIDENTIAL | SIZE | A |
| 2 | 169008 | 1 | 07+ Sprinter Van LED Light - 19.75" Rib Asm. | | | THE INFORMATION CONTAINED IN THIS DRAWING IS THE SOLE PROPERTY OF J&M TRUCK BODIES. ANY REPRODUCTION IN PART OR AS A WHOLE WITHOUT THE WRITTEN PERMISSION OF J&M TRUCK BODIES IS PROHIBITED. | Drawn By. J. Chauvin | SCALE: 1:24 |
| 1 | 169009 | 2 | 07+ Sprinter Van LED Light - 21.75" Rib Asm. | | | | | 1 |
| # | PART NO. | QTY. | DESCRIPTION | | | | | 5 |