

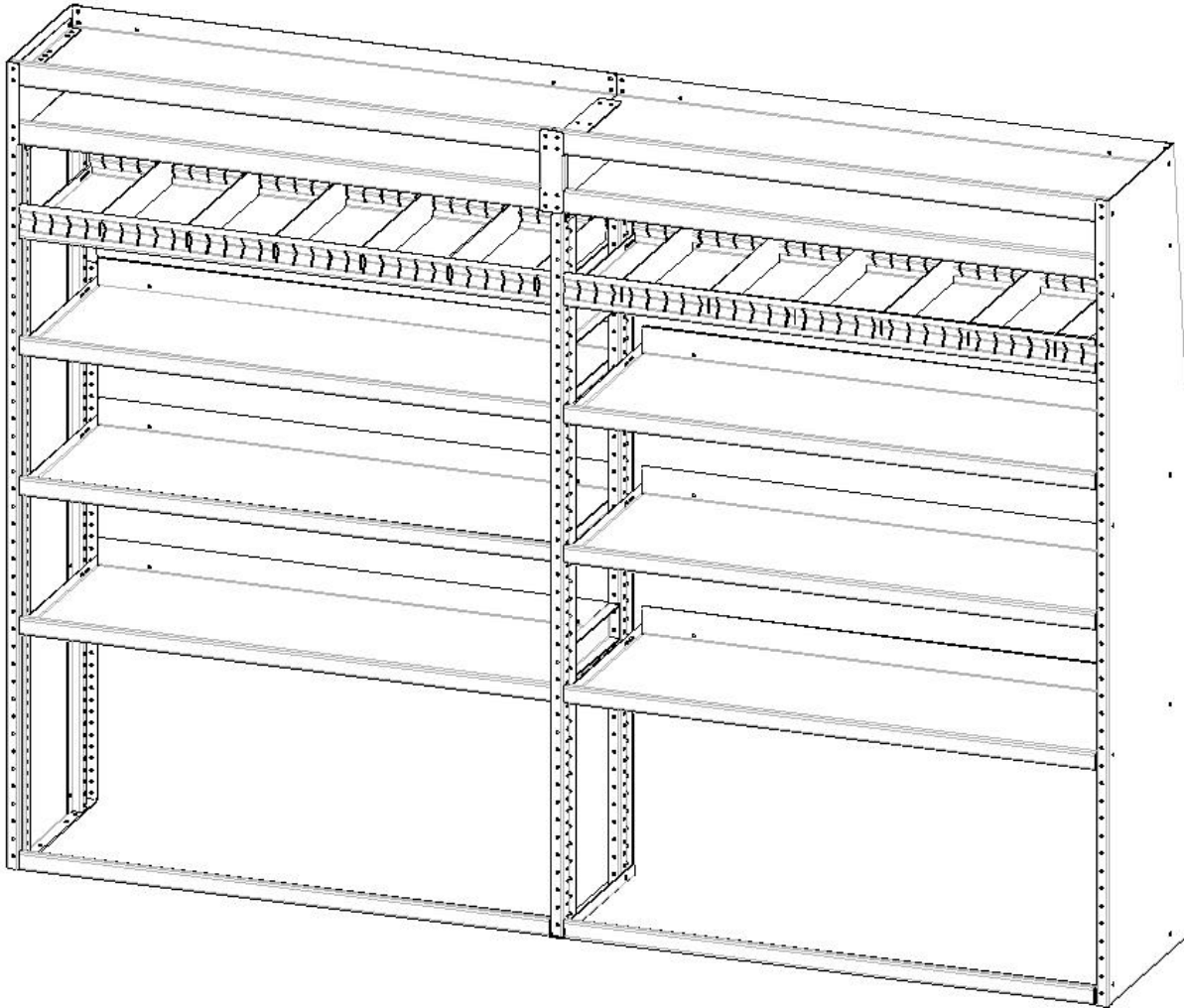



# Assembly Guide

## Double Section Tapered Shelving with Pipe Tray



	<b>A</b>	¼-20 x 5/8" Pan Head Bolt		<b>B</b>	¼-20 x 5/8" Hex Head Flanged Bolt
	<b>C</b>	¼-20 x 5/8" Flat Head Bolt		<b>D</b>	#10 x 1" Self-drilling Tek Screw

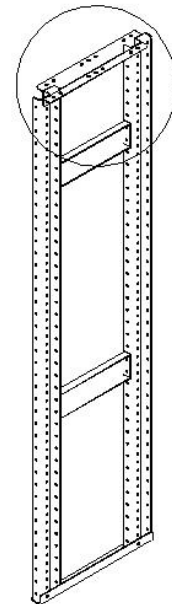
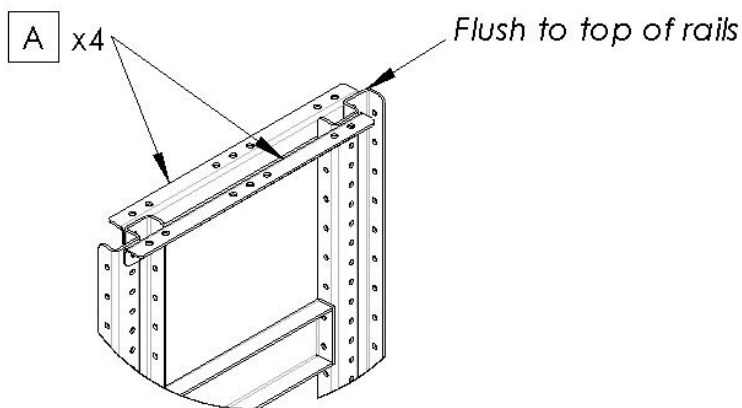
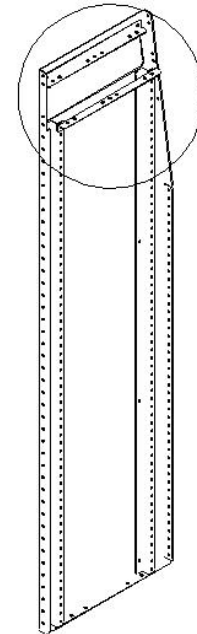
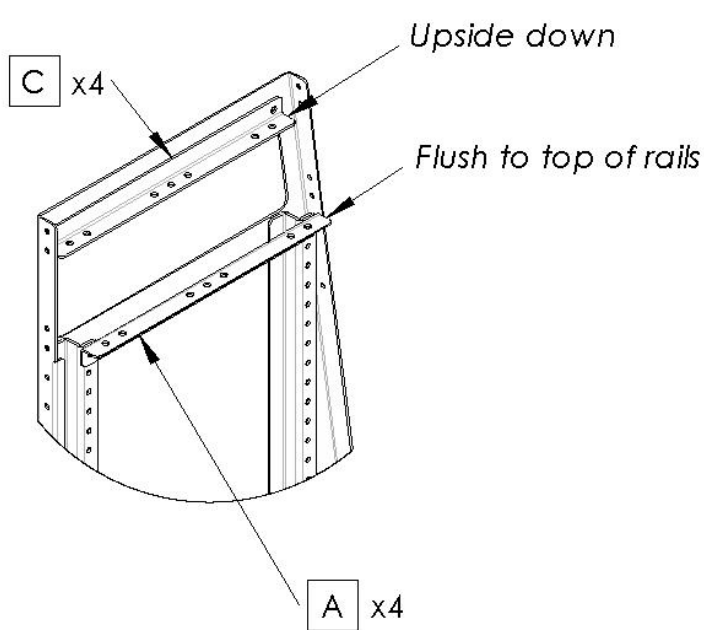

## Step 1

- Bolt two L-bracket to each End Panel
- Bolt two L-brackets to the Center Support

*Note: L-brackets must be flush to the top of the rails*

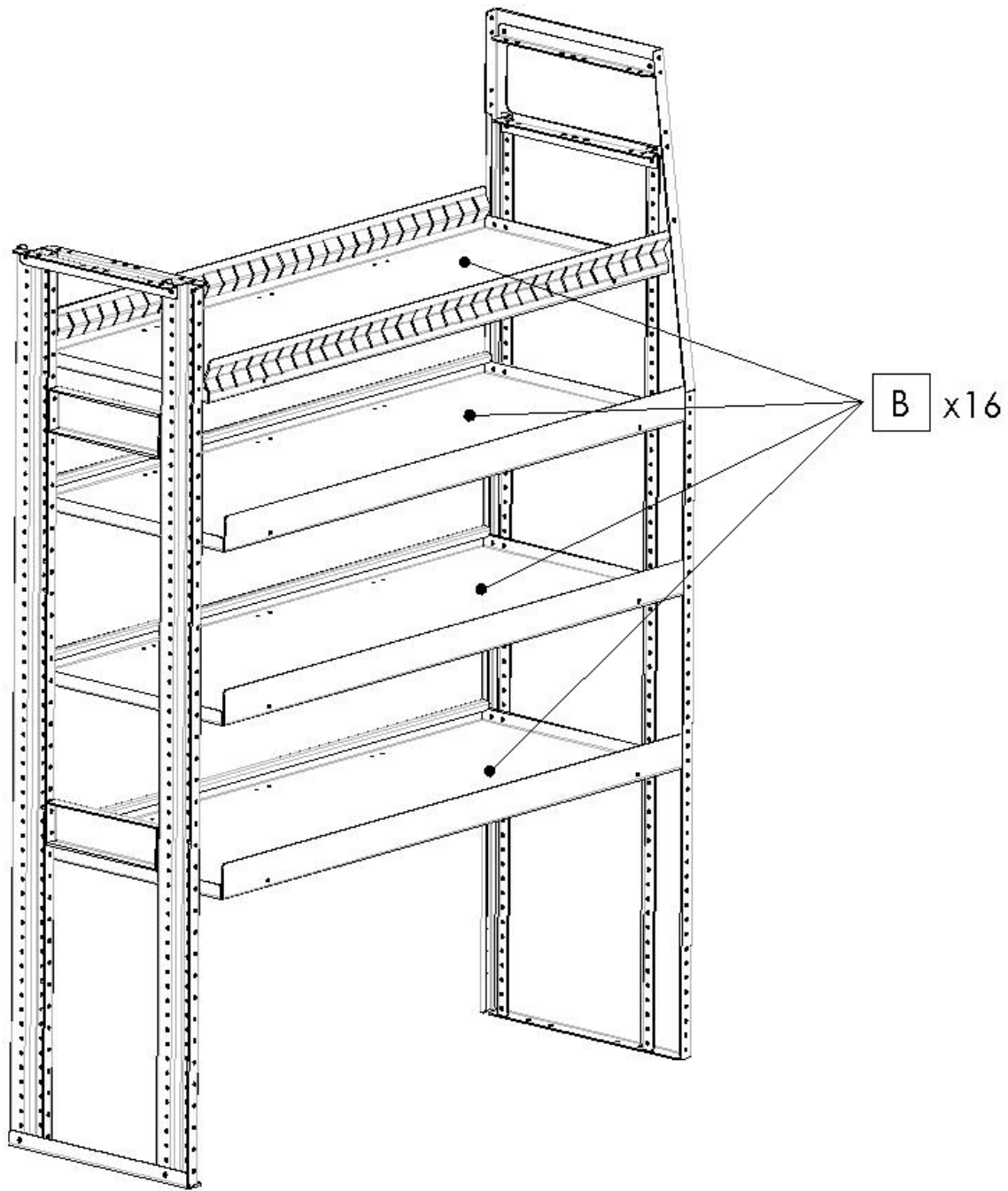

## Step 2

- Install the shelves for the first section from top to bottom

### Note:

- This is most easily done with shelving unit face down on a level surface
- Slotted holes on each shelf go to the back rail
- Measure and mark on the rails the desired shelf heights
- The topmost shelf is shallower. Lower shelves are full depth.
- Shelves may be mounted upside down or tilted up/down to fit your needs

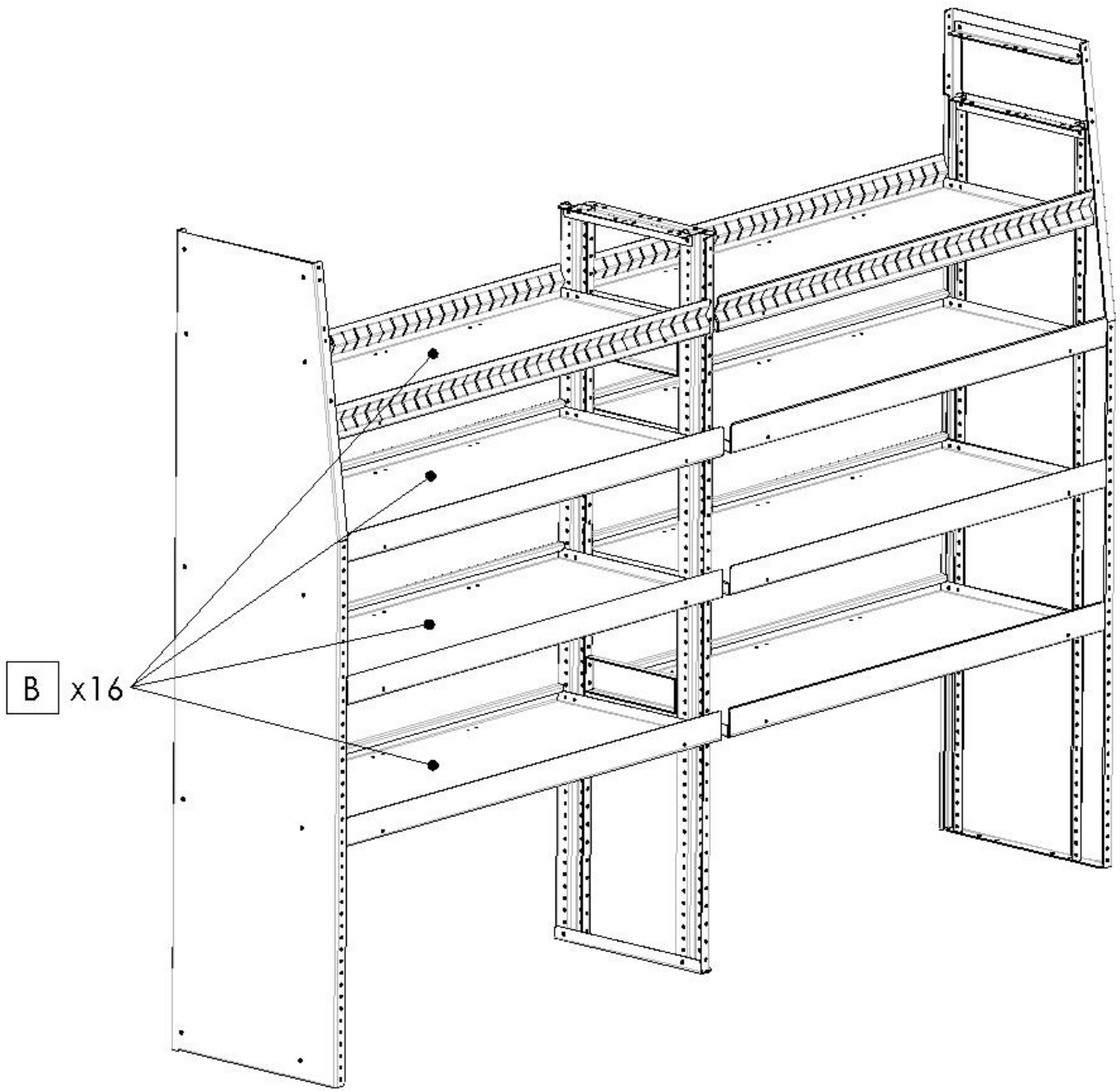

### Step 3

- Install the shelves for the second section from top to bottom.

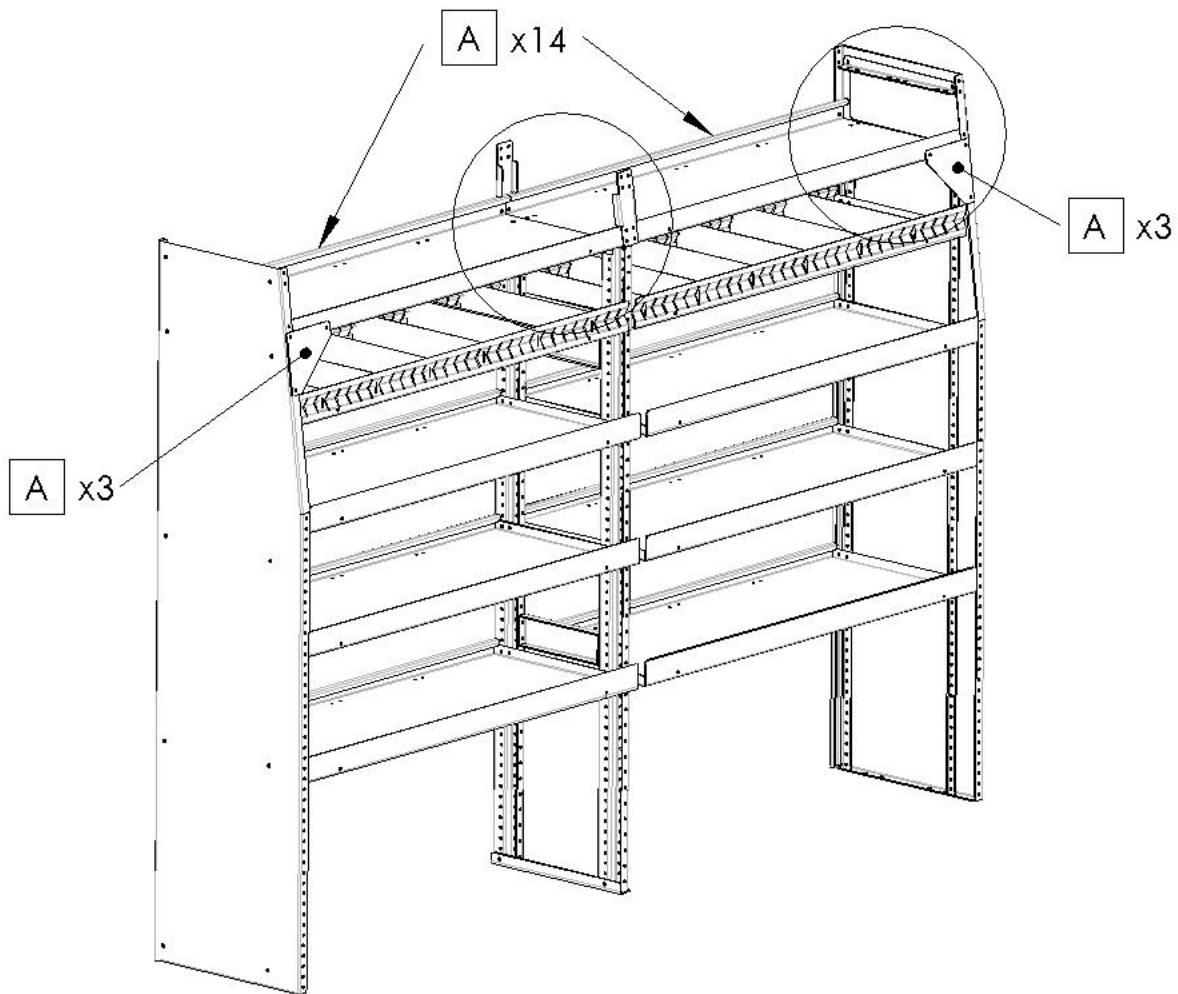
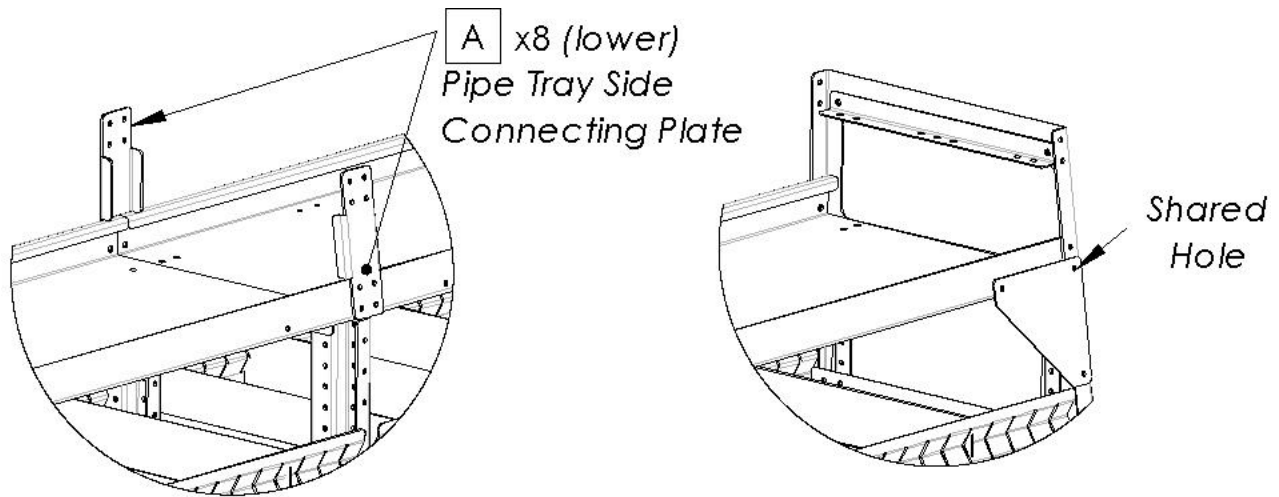

## Step 4

- Install the two lower Pipe Trays and the two Angle Supports
- Bolt the two Side Connecting Plates on the front and back of where the pipe trays meet in the middle. Do not fully tighten until the upper Pipe Trays are installed

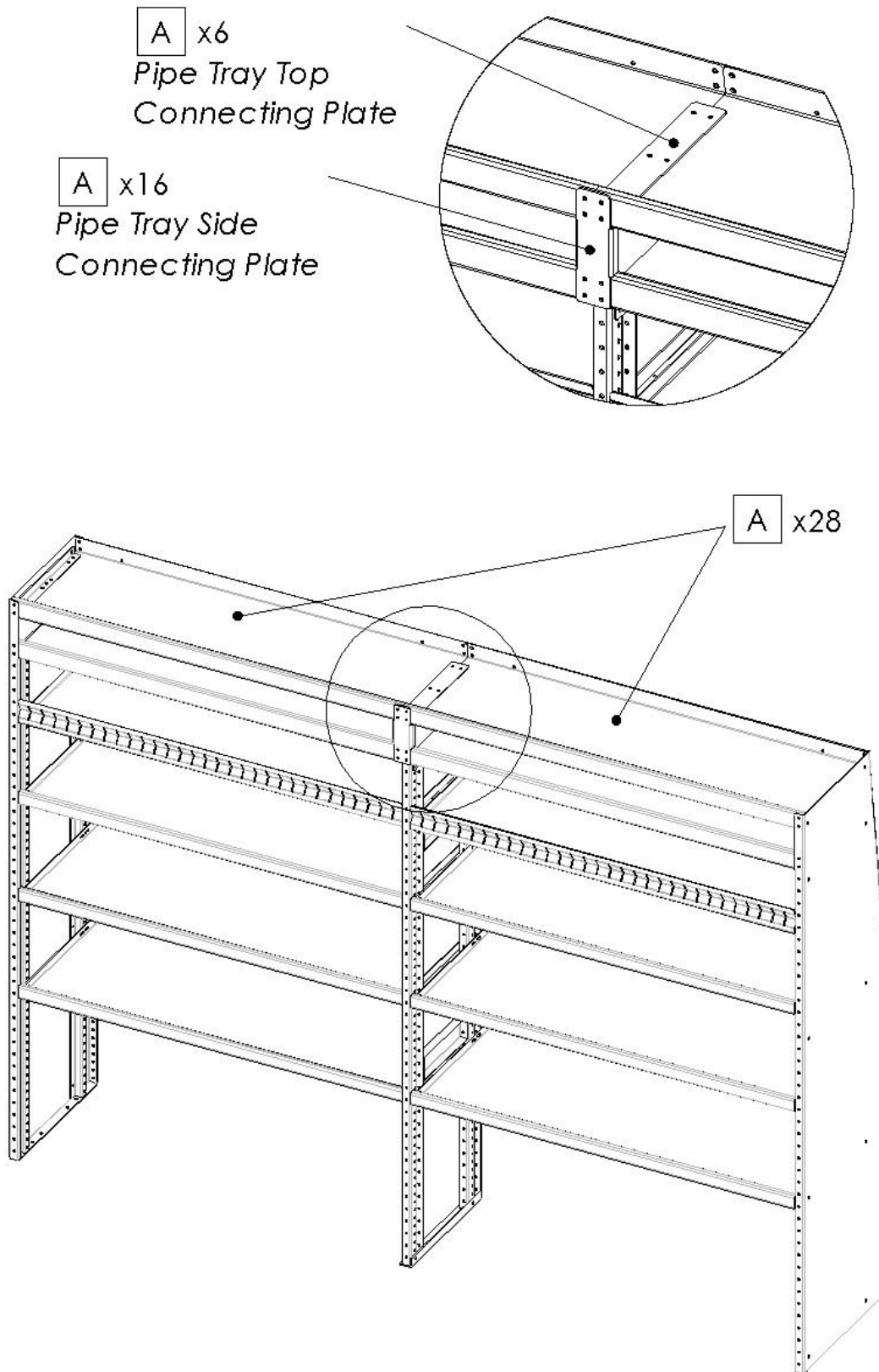

## Step 5

- Install the two upper Pipe Trays. They meet in the center where they bolt to the Side Connecting Plates
- Bolt the Top Connecting Plate to the underside of the upper Pipe Trays

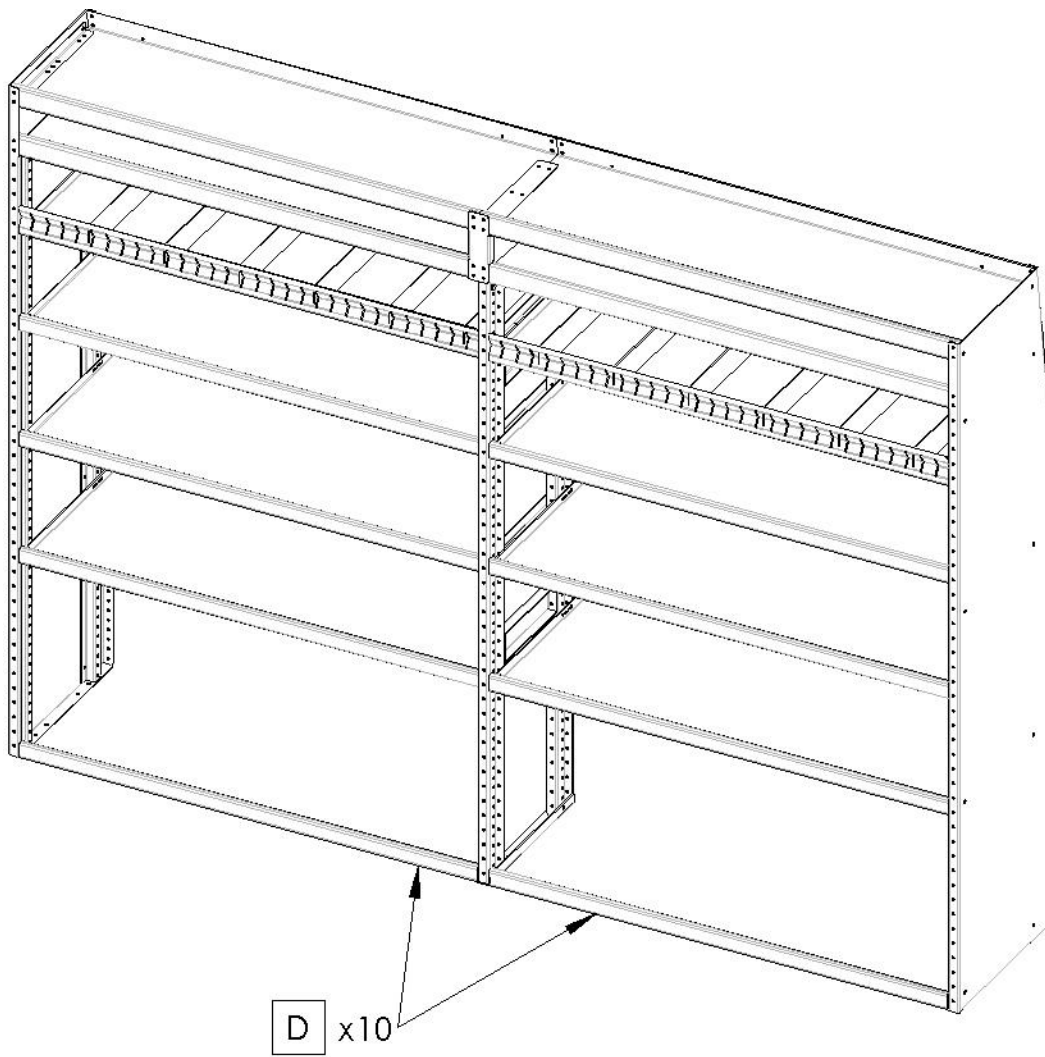

## Step 6

- Check all bolts are tight
- Lift the shelving unit into the van and use the provided installation hardware to fasten it to the wall and floor. Follow the install guide.
- Screw each bottom lip to the floor (optional).
- Insert the slotted shelf dividers at desired spacing (if applicable).

*Note: Slightly twisting each divider will allow for a tighter and quieter fit*