

- All shelves adjustable in 1" increment

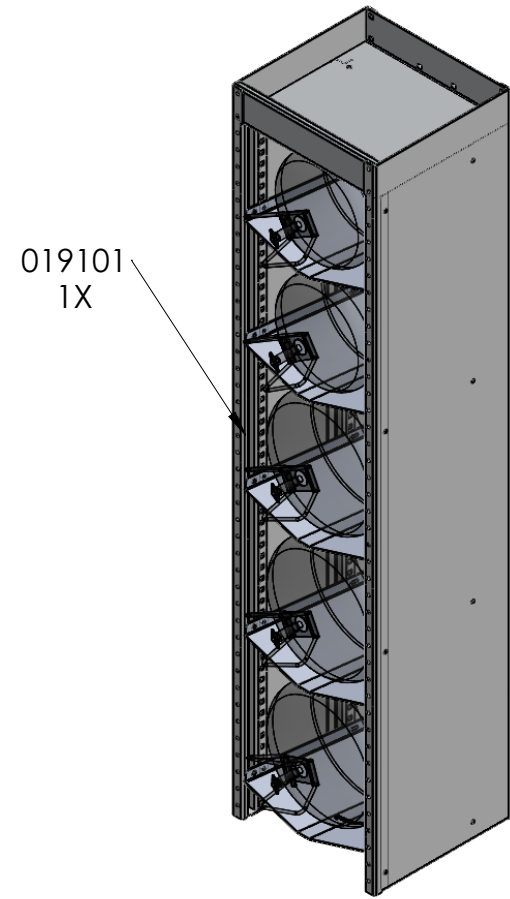
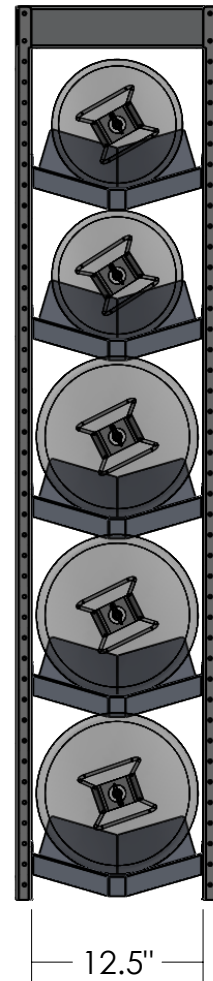
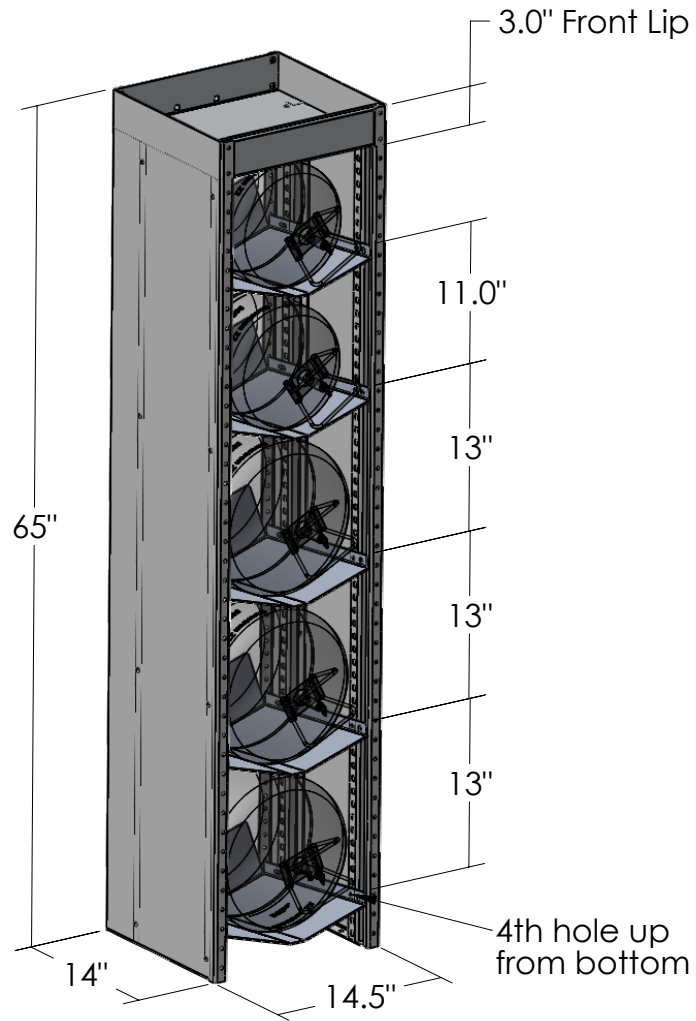

3	649202	1	Bottle Holder Tower - Hdw Kit
2	647031	5	Bungy Cord - 3/16" Diameter X 12" Long Overall
1	019101	1	Freon Tank Tower - 14"D x 65"T x 14.5"W - Asm.
#	PART NO.	QTY.	DESCRIPTION

5

4

3

Rev. Weight
 -- 241,34525 Lbs.



7541 Chapman Ave Unit B
 Garden Grove, Ca 92841

Description	Freon Tank Tower - 14"D x 65"T x 14.5"W - Holds 50# (x3) + 30# (x2) or Holds 50# (x4)		
Material	Aluminum	Item No.	010101
<small>THE INFORMATION CONTAINED IN THIS DRAWING IS THE SOLE PROPERTY OF J&M TRUCK BODIES. ANY REPRODUCTION IN PART OR AS A WHOLE WITHOUT THE WRITTEN PERMISSION OF J&M TRUCK BODIES IS PROHIBITED.</small>		SIZE	Date
		A	3/11/2021
		Drawn By.	S.Gutierrez
		SCALE:	1:24

2

1