

Notes:  
 \*500Lbs. Lifting Capacity  
 \*Powdercoated Black

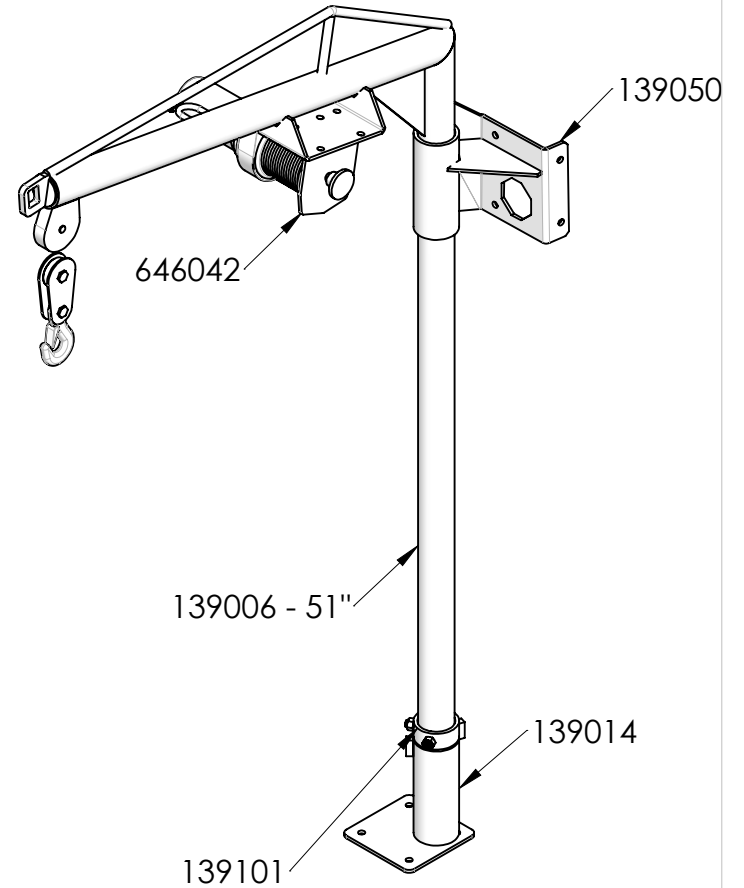

| 8 | 139101       | 1    | Pivot Tube Stop Asm                               |
|---|--------------|------|---|
| 7 | 131045       | 1    | Pulley w/ Axle and Cotter Pin                     |
| 6 | 646001       | 1    | Winch Pully Block - Attached to Cable on Motor    |
| 5 | 646042       | 1    | Winch Motor - Steel Line 12v With Handheld Remote |
| 4 | 649154       | 1    | Hoist Electrical Hardware Kit (not shown)         |
| 3 | 139050       | 1    | 13+ RAM ProMaster - Upper Mount Asm. - Side LR    |
| 2 | 139014       | 1    | Lower Mount Asm. - Corner Base Plate - 5"L x 5"W  |
| 1 | 139006 - 51" | 1    | Boom Asm. - 10° x 30" Jib   Cut boom to 51"       |
| # | PART NO.     | QTY. | DESCRIPTION                                       |

Rev. Weight  
 -- 41.94 Lbs.

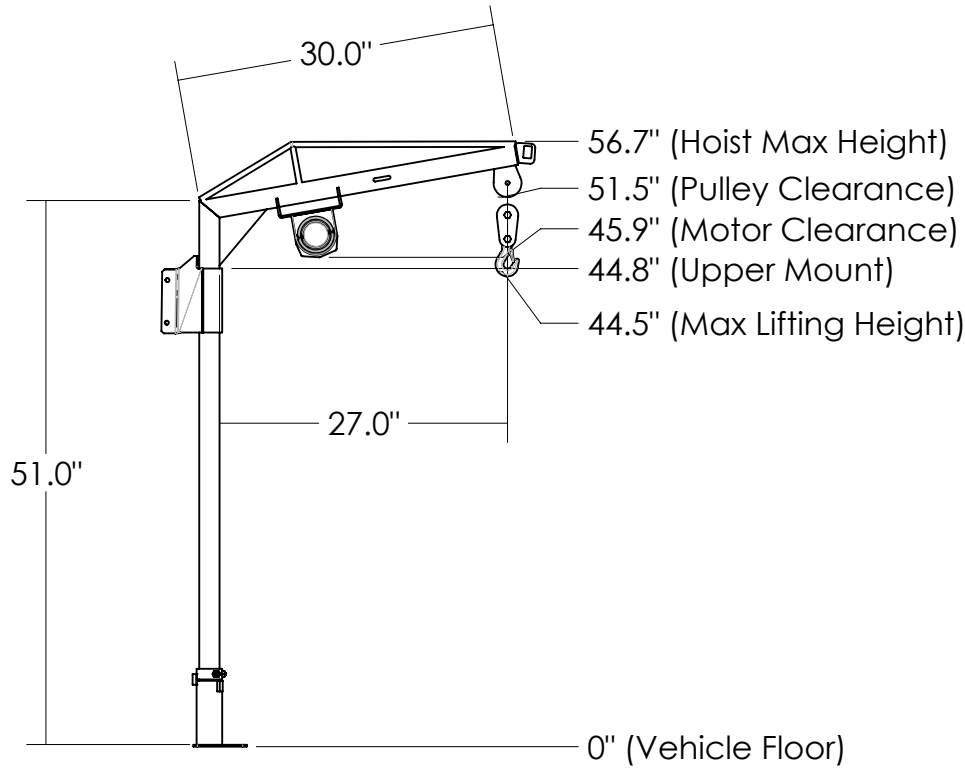
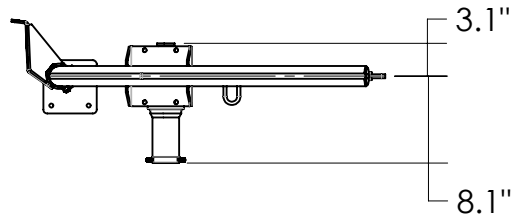

7541 Chapman Ave Unit B  
 Garden Grove, Ca 92841

|   |  |             |                       |
|---|--|-------------|-----------------------|
| Description   | 13+ RAM ProMaster - 12V Electric Hoist Kit - Side LR |             |                       |
| Material  | Steel  | Item No.    | 130038                |
| <small>THE INFORMATION CONTAINED IN THIS DRAWING IS THE SOLE PROPERTY OF J&amp;M TRUCK BODIES. ANY REPRODUCTION IN PART OR AS A WHOLE WITHOUT THE WRITTEN PERMISSION OF J&amp;M TRUCK BODIES IS PROHIBITED.</small> |  | SIZE        | Date                  |
| <b>A</b>  |  | 5/3/2021    | Drawn By: S.Gutierrez |
|   |  | SCALE: 1:18 |                       |

5

4

3

2

1