

FITS:

- Milwaukee Packout Bin - 48-22-8432

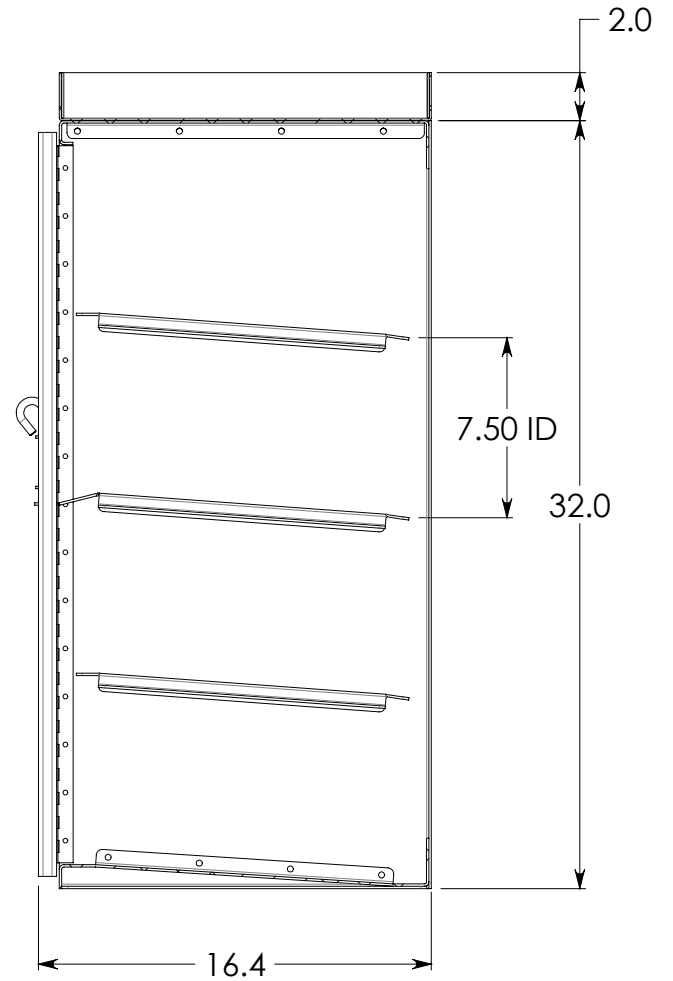
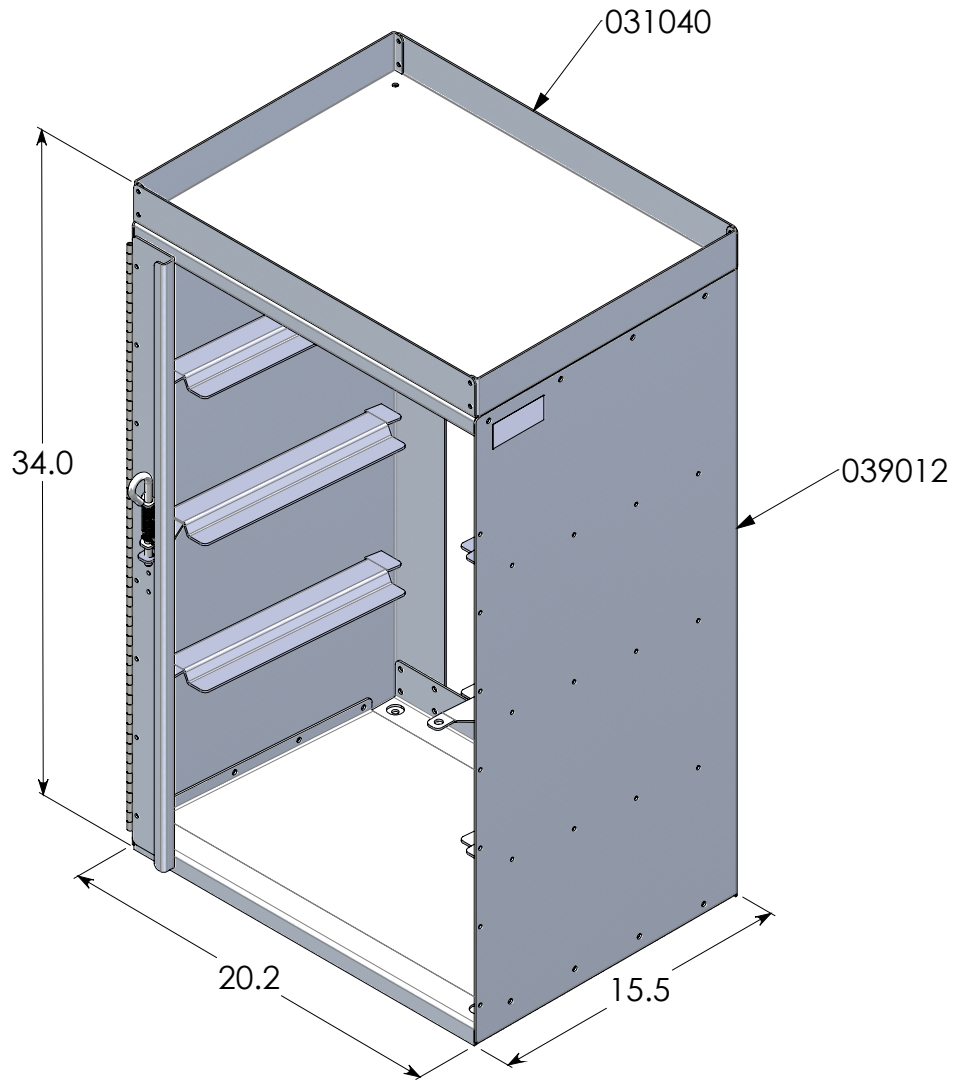

NOTE: All Dimensions Are OD Unless Otherwise Noted

5	642062	4	1/4"-20 X 5/8" Pan Head Bolt - Zinc
4	642121	4	#14 X 1" Flange Hex Head Screw
3	642040	32	#10-24 X 5/16" Flat Head Machine Screw - Zinc (Under Cut)
2	031040	1	Parts Organizer - Top Tray (Milwaukee Packout)
1	039012	1	Parts Organizer - Bottom (Milwaukee Packout)
#	PART NO.	QTY	DESCRIPTION

Rev. Weight
-- 26.41 Lbs.



7541 Chapman Ave Unit B
Garden Grove, Ca 92841

Description Parts Organizer Tower - 20"W x 15.5"D x 32"H - Fits 4 (Large Milwaukee Packout)

Material 5052 Smooth Alum. Item No. 030012

PROPRIETARY AND CONFIDENTIAL THE INFORMATION CONTAINED IN THIS DRAWING IS THE SOLE PROPERTY OF J&M TRUCK BODIES. ANY REPRODUCTION IN PART OR AS A WHOLE WITHOUT THE WRITTEN PERMISSION OF J&M TRUCK BODIES IS PROHIBITED. SIZE Date 4/26/2024

Drawn By. J. Chauvin SCALE: 1:8

5

4

3

2

1