

FITS:

- 3pcs Milwaukee Packout Bin - 48-22-8430
- 2pcs Milwaukee Packout Bin - 48-22-8432

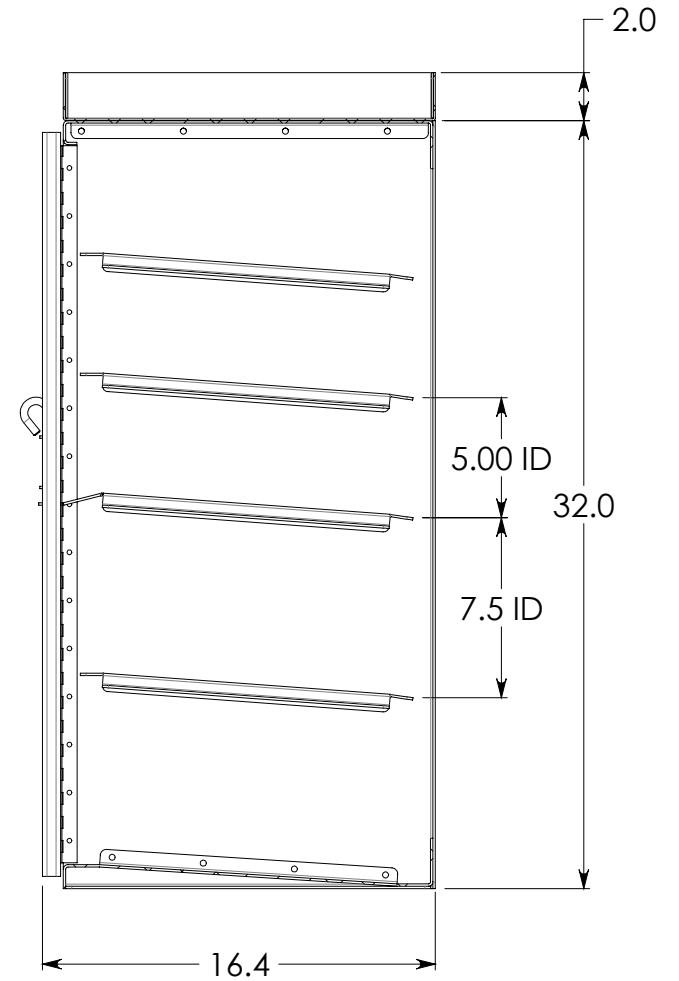
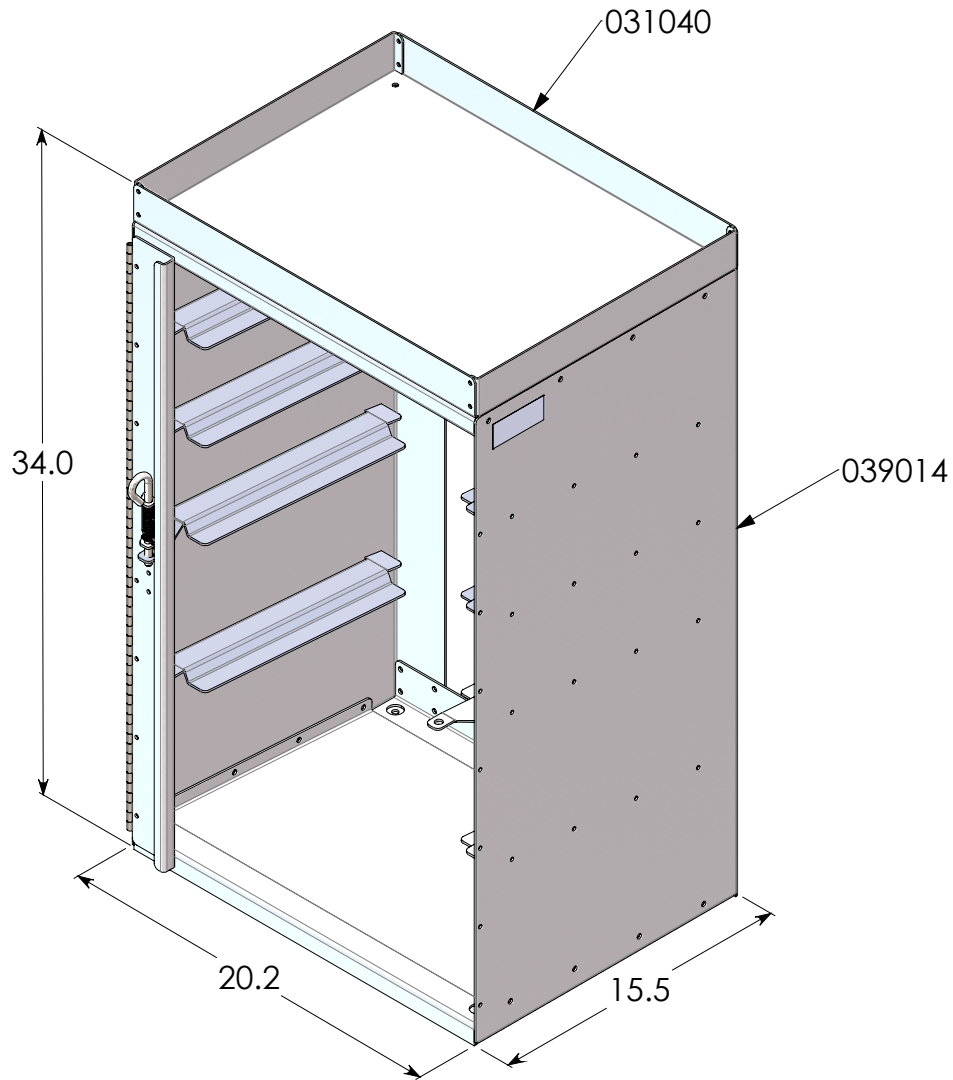

NOTE: All dimensions are OD unless otherwise noted

5	642062	4	1/4"-20 x 5/8" Pan Head Bolt - Zinc
4	642121	4	#14 x 1" Flanged Hex Head Screw
3	642040	32	#10-24 x 5/16" Flat Head Machine Screw - Zinc (UnderCut)
2	031040	1	Parts Organizer - Top Tray (Milwaukee PackOut)
1	039014	1	Parts Organizer - Bottom (Milwaukee PackOut)
#	PART NO.	QTY.	DESCRIPTION

Rev. Weight
-- 27.23 Lbs.

7541 Chapman Ave Unit B
Garden Grove, Ca 92841

Description Parts Organizer Tower - 20"W x 15.5"D x 32"H - Fits 2 Large & 3 Small (Milwaukee Packout)

Material 5052 Smooth Alum. Item No. 030014

PROPRIETARY AND CONFIDENTIAL
THE INFORMATION CONTAINED IN THIS DRAWING IS THE SOLE PROPERTY OF J&M TRUCK BODIES. ANY REPRODUCTION IN PART OR AS A WHOLE WITHOUT THE WRITTEN PERMISSION OF J&M TRUCK BODIES IS PROHIBITED.

SIZE Date 4/26/2024
A Drawn By J. Chauvin
SCALE: 1:8

5

4

3

2

1