

Notes:
 *500Lbs. Lifting Capacity
 *Powdercoated Black

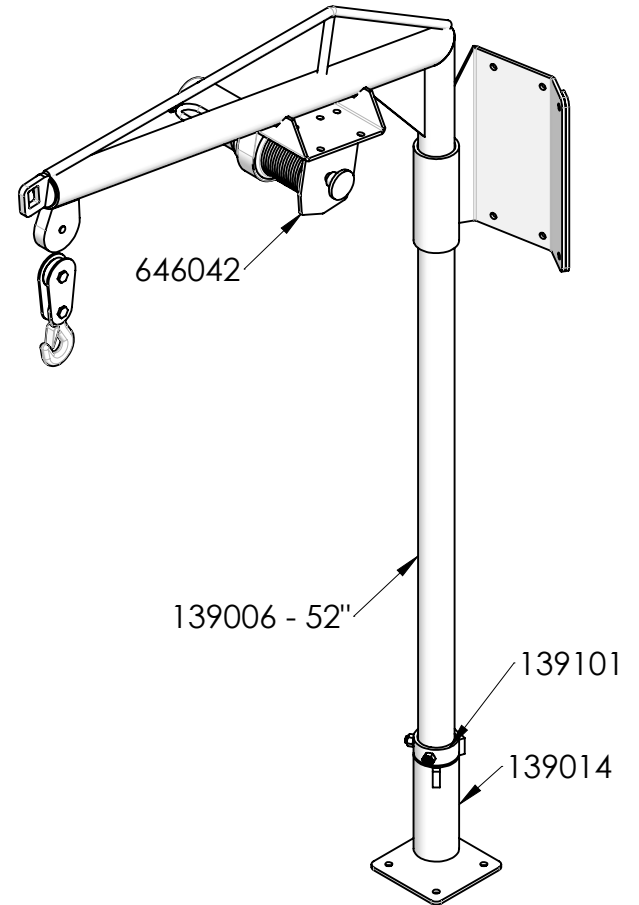

12	642277	6	3/8"-16 x 1-1/4 Grade 8 Hex Bolt - Yellow-Chromate
11	642252	6	3/8" SAE Flat washer - Zinc
10	642251	6	3/8" Lock Washer - Zinc
9	642205	3	5/16 x 1-1/4" - Flanged Hex Head Sheet Metal Screw
8	646001	1	Winch Pully Block - Attached to Cable on Motor
7	646042	1	Winch Motor - Steel Line 12v With Handheld Remote
6	649154	1	Hoist Electrical Hardware Kit (not shown)
5	131045	1	Pulley w/ Axle and Cotter Pin
4	139042	1	Upper Mount Asm. - 13+ RAM ProMaster - Rear LR Driver
3	139101	1	Pivot Tube Stop Asm
2	139014	1	Lower Mount Asm. - Corner Base Plate - 5"L x 5"W
1	139006	1	Boom Asm. - 10° x 30" Jib Cut boom to 52"
#	PART NO.	QTY.	DESCRIPTION

Rev. Weight
 -- Lbs.

JM
 7541 Chapman Ave Unit B
 Garden Grove, Ca 92841

Description 13+ RAM ProMaster - 12V Electric Hoist Kit - Rear LR Driver

Material Steel Item No. 130036

PROPRIETARY AND CONFIDENTIAL THE INFORMATION CONTAINED IN THIS DRAWING IS THE SOLE PROPERTY OF J&M TRUCK BODIES. ANY REPRODUCTION IN PART OR AS A WHOLE WITHOUT THE WRITTEN PERMISSION OF J&M TRUCK BODIES IS PROHIBITED.
 SIZE Date 5/3/2021
A Drawn By: S.Gutierrez
 SCALE: 1:18