

Sprinter Van Pro Plus Package

SP5103

07+ Sprinter - High Roof - 170" Wheel Base - Dual Rear Wheel

- » Durable & lightweight aluminum construction
- » 18" deep fully adjustable shelves maximize storage space
- » Easy & secure storage for full length pipe

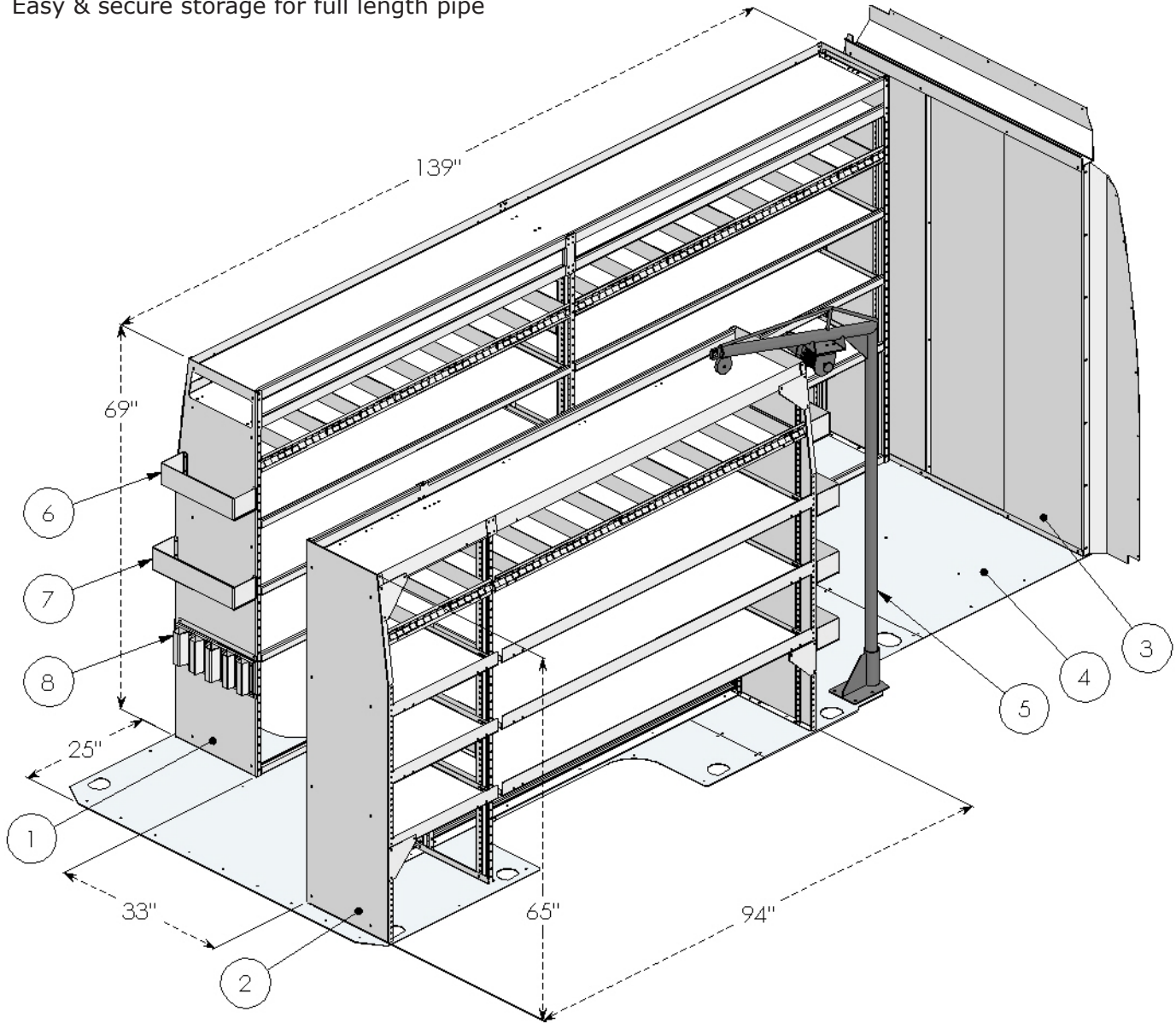

#	DESCRIPTION	QTY.	ITEM NO.
1	Pipe Tray Shelving Unit 4 shelves	1	360061
2	Standard Shelving Unit 4 shelves	1	360017
3	Headboard Solid, No window	1	110070
4	Flooring Treadbrite	1	100037
5	Hoist	1	130022
6	Tray 16"W x 4"H x 5"D	2	530120
7	Tray 18"W x 4"H x 5"D	4	530122
8	Wrench Holder 3 Large, 2 Small	1	530029

Options are available for items in this package

Comes with: 140020

